



Sicher Elevator Co.,Ltd.

Address: NO.1 Sicher Road, Lianshi Industrial Park, Huzhou City, Zhejiang, China
Tel: +86-572-2923382/2923126 400-887-5898
Fax: +86-572-2923121
Http://www.sicher-elevator.com
E-mail: srh@sicher-elevator.com
P.C: 313013

Official Distributor

PT.Risosa Nusantara Mandiri
General Contractor & Mechanical / Electrical Supplier
021-5239-4123

Alamat: Rukan Sedayu Square Blok K no.1 Jl. Kamal Outer Ring Road
Cengkareng,
Kecamatan Cengkareng, DKI Jakarta 11730
WWhatsapp: +62 811 869 286 (Aldo)
E-mail: risosamandiri@gmail.com
sicherelevator.co.id

SRH
SAFE REACH

SICHER ELEVATOR

All for Safe Reach

Sicher Elevator Co.,Ltd.



Sicher Elevator Co.,Ltd.

SRH, originates from German word "Sicher", which means safe, reliable, and reflects the core value of the brand about "all for safe reach" throughout and constantly in the complete process of product R&D, manufacturing, sales, installation and service.

Sicher Elevator Co., Ltd. is a specialized, collectivized transnational operation enterprise through investment, merger and stock restructuring.

Sicher covers an area of 147,600 square meters, with overall floorage 170,000 square meters, owns eight functional areas, including headquarters office center, product manufacturing center, R & D center, customer service center, elevator testing center, electrical control center, international communication center and logistics center, deeply combined industrialization with informatization, which is a large-scale and global market-oriented manufacturing enterprise for elevators, escalators and parking system equipment.

SRH Aufzüge GmbH, as a wholly owned subsidiary by Sicher Elevator Co., Ltd. builds the close strategic cooperation union with German large, medium-sized elevator manufacturing companies and elevator parts companies to provide all kinds of **SRH** brand products in line with EU Standards for global customers.

Sicher implements the scientific and technological innovation development strategy and establishes several innovation platforms such as Provincial Enterprise Research Institute, Academicians and Experts Workstation,

Provincial Post-doctor Scientific Research Workstation, Provincial Enterprise Technology Center, Provincial Industrial Design Center, Provincial High-tech Enterprise Research and Development Center, Sicher Elevator Center Laboratory, China Academy of Building Research-Sicher Elevator R&D Center, Zhejiang Sicher Elevator Science and Technology Research Institute. It owns over 150 patents and won the honor of "The National Machinery Industry Outstanding Unit". Its quality management has passed the national military standard attestation. Elevator product was awarded US "Elevator World Project" and moving walk product was awarded "China Records".

With perfect service network at home and abroad, Sicher has exported its products to over 80 countries and regions and has established a long-term strategic cooperative partnership with many renowned real estate development enterprises and won the honor of "National Excellent Supplier in Government Procurement". SRH has become a well respected elevator brand in Russia, Australia, Turkey, Mexico, Brazil, New Zealand, UAE, India, Egypt, Iran, Bangladesh, South Africa, etc.

Sicher Elevator persists in the development strategy of "internationalization, technology, industrialization" and takes the innovation of service, technology and idea as its core to realize a new value eco of intelligent manufacturing, industrial service and international brand further to spare no effort to become a world excellent elevator solutions service provider.



A bird's view of the factory zones

It strictly accords with the professional, collective and international factory design standard. It establishes 8 functional zones such as office, R&D, electric control, manufacture, testing, customer service, logistics, International Cooperation etc. with the scientific planning and reasonable arrangement.

Business Archives Stadium



Business Exhibition Hall



Business Exhibition Hall



Powerful R&D Center

- 1** East Hall of Headquarters Building
- 4** International Trading Center
- 7** Headquarters Building Office
- 10** Logistics Center

- 2** VIP Reception Hall
- 5** Video Conference Center
- 8** International Cooperation Center

- 3** Business Rest Hall
- 6** Sales Center
- 9** Product Manufacturing Center

108m



Advanced equipments

16 production lines,
top-grade manufacture
craft & tech

Sicher Elevator has introduced 16 advanced production lines, including full-automatic flexible metal plate production line, medium thick metal plate production line, control system production line, robot welding production line and automatic spraying production line, etc. It owns a full set of modern NC machining equipment and detection equipment on key and safety components, so as to ensure the product quality.



SRH Aufzüge GmbH

A wholly owned subsidiary by Sicher Elevator Co., Ltd.

SRH Aufzüge GmbH is an integrated multinational enterprise that develops, carries out research on and manufactures elevators, control systems and other core components.

The company is located in Bremen, the second-largest port city in Germany and the manufacturing base of large electronics, shipbuilding, and steel industry enterprises such as Mercedes-Benz, and Europe's largest aerospace manufacturer Airbus; Bremen not only is one of the largest educational centres and technology parks; it is also the second-largest foreign trade hub in Germany and the world's largest port city for the motor vehicle trade.

In Germany, as a member of VFA-Interlift e.V., SRH Aufzüge GmbH has participated in the drafting of the EU standards and norms for elevators. It has formed close strategic alliance with German large and medium-sized complete elevator and elevator parts manufacturing companies with a long history of manufacturing and gradually established an international territory centered in Germany and extending to regions all over the world.

In China, Sicher introduces Germany advanced technology and management mode. In the meanwhile, SRH Aufzüge GmbH provides control system, traction machine, door operator and other core components for Sicher Elevator Co., Ltd., jointly R&D and manufacture elevator, escalator with Germany industrial quality.

SRH Aufzüge GmbH adheres to safety as its core brand value and is committed to being the safest elevator manufacturer and service provider, supplying original SRH brand elevators made in Germany to customers worldwide.

Qualification certificate

High standard fulfills high quality



Product series

It provides global transport with all-round solution plans.

The perfect vertical transport solution plan

Sicher Elevator Co., Ltd. provides series products of high speed elevator, small machine room / machine roomless passenger elevator, observation elevator, bed elevator, fireman elevator, freight elevator, car elevator, escalator, moving walk and three dimensional parking system, which provide vertical traffic solution for all kinds of buildings in the world, such as public building, commercial building, residential building, industrial building and so on.

Product	Type	Load Range (kg)	Speed Range (m/s)
Passenger Elevator	GRPS20	400~2000	1.0/1.75/2.0/2.5/3.0/3.5/4.0
	GRPS30	630~1600	1.0/1.75/2.0
	GRPS50	630~1050	1.0/1.75/2.0
	GRPS70	1000~1600	4.5/5.0/5.5/6.0/6.5/7.0/8.0
	GRPN20	400~1600	1.0/1.6/1.75/2.0
	GRPS20F	800~1600	1.0/1.75/2.0/2.5
Bed Elevator	GRBS	1000~2000	1.0/1.75/2.0/2.5
Observation Elevator	GROS	630~1600	1.0/1.75/2.0/2.5
Home Elevator	GRV20	250~400	0.22/0.28/0.3/0.4
Car Elevator	GRA10	3000~5000	0.25/0.5
Freight Elevator (Traction)	GRF	1000~5000	0.25/0.5/1.0
Freight Elevator (Hydraulic)	GRFH10	1000~5000	0.25/0.5

Product	Type	Inclination	Step (pallet) Width	Rise/Span
Escalator (Commercial)	GRE20	27.3°	600/800/1000	H≤7.5m
		30°	600/800/1000	H≤7.5m
		35°	600/800/1000	H≤6m
	GRE30	27.3°	600/800/1000	H≤16m
		30°	600/800/1000	H≤16m
Escalator (Public traffic)	GRE50	27.3°	600/800/1000	H≤30m
		30°	600/800/1000	H≤30m
Moving walk	GRM20	10°/11°/12°	800/1000	H≤8m
	GRM15	0°-6°	800/1000	L ≤150m

GRPS20 small machine room passenger elevator

GRPS20 small machine room passenger elevator, fusion of Germany's strict manufacturing technology and the industry of advanced technology, optimize the design of space, mechanical components of smart compact, effectively reduce the top space, save the cost of construction; also has energy-saving environmental protection, safe and stable, comfortable experience and other advantages, for all types of modern buildings provide reliable solutions.



GRPN20 machine roomless passenger elevator

We know very well about the consumption reduction and energy-saving, environmental protection ideas for GRPN20 machine roomless passenger elevator. With great improving on design freedom of motion & full expressing on green humanities, we endeavor to save the building area, enhance the freedom in design, fully display a green and human concept. Compared with same loading level geared elevator, it can save more electricity and building area. GRPN20 machine roomless passenger elevator breaks through the premise that every elevator needs to have a machine room. It offers an inventive possibility for the limited space in the modern constructions.





GRPS30 small machine room passenger elevator

Compared with Sicer last generation machine room elevators, GRPS30 series of small machine room passenger elevators have more compact construction layout, only taking up about 25% of room area of traditional machine room, the hoistway section is further narrowed by about 20%, the top height has a decrease of 300-500mm, the pit depth decreases 100-300mm. Exchange for spacious riding space with appropriate building area.

GRPS50 small machine room passenger elevator

GRPS50 small machine room passenger elevator adopts the original core components from SRH Aufzüge GmbH, which blends safety, energy saving, quiet and other advanced technologies. The functional configuration is upgraded to a new level, provide a better transportation quality. This product suitable for public facilities projects, such as high-end office buildings, apartments, hotels and airports and so on.

GRPS70 high speed elevator

With the quantity and height increase of modern city high-rise building, people have high requirements to the efficiency and innovation of building vertical transportation. Sicer GRPS70 series high speed elevator has been created at the right time, which breaks through a number of problem of high speed elevator, creates efficiency and convenience vertical transportation solution for high-rise building through optimizing the drive system, intelligent function, selecting the excellent materials and innovative design, to provide more advantages and value for various landmark buildings.

GRPS20F Fireman elevator

Sicer Elevator has a high sense of mission to protect the safety of passengers, who actively develops in the field of fireman elevator firstly to building the perfect function fireman elevator in the real sense. At present, Sicer Elevator walks in forefront in the elevator industry due to its mature research, development and installation technology to manufacture the fireman elevator.



GRO observation elevator

We introduce a full set of German control technology and apply modern materials and the latest processing craft & technique to produce GRO serial observation elevator products. This kind of products have the most perfect performance in lots of aspects such as the travel quality, safety functions, car model design, energy-saving and consumption reduction etc.



RJ100 (Standard)
 Car cover: Baked enamel steel plus color decoration patterns
 Observation wall: Laminated safety glass
 Decoration roof: Round acrylic lamp in the middle, down lights on two sides
 Car wall: Hairline stainless steel
 Handrail: Stainless steel tube
 Floor: PVC



RJ101 (Standard)
 Car cover: Baked enamel steel with acrylic lighting decoration
 Observation wall: Laminated safety glass
 Decoration roof: Hairline stainless steel frame, acrylic light-emitting panel, down lights
 Car wall: Hairline stainless steel
 Handrail: Stainless steel tube
 Floor: PVC



RJ102 (Optional)
 Car cover: White acrylic decoration hood
 Observation wall: Laminated safety glass (three pieces)
 Decoration roof: Baked enamel steel frame and blue acrylic lighting strip
 Car wall: Hairline stainless steel
 Handrail: Stainless steel tube
 Floor: PVC



RJ103 (Optional)
 Car cover: Baked enamel steel with lighting decoration
 Observation wall: Laminated safety glass
 Decoration roof: Mirror st./st. with acrylic plate
 Car wall: Laminated glass
 Handrail: Stainless steel tube
 Floor: PVC



RJ105 (Standard)
 Car cover: Baked enamel steel frame, acrylic lighting decoration
 Observation wall: Laminated safety glass
 Decoration roof: Steel plate baked enamel frame, acrylic roof lamp with down lights
 Car wall: Hairline stainless steel
 Handrail: Stainless steel tube
 Floor: PVC



RJ107 (Optional)
 Car cover: Baked enamel and lighting decoration
 Observation wall: Laminated safety glass
 Decoration roof: Baked enamel steel frame, acrylic lighting decoration
 Car wall: Polychrome st./st.
 Handrail: Stainless steel tube
 Floor: PVC



RJ108 (Optional)
 Car cover: Baked enamel steel, acrylic lighting decoration
 Observation wall: Laminated safety glass
 Decoration roof: Baked enamel steel frame, acrylic arch top plate with down lights
 Car wall: Hairline stainless steel
 Handrail: Stainless steel, single tube fixed on floor
 Floor: PVC



RJ109 (Optional)
 Car cover: Baked enamel steel, acrylic and LED down lights
 Observation wall: Laminated safety glass
 Decoration roof: Hairline st./st. with acrylic plate
 Car wall: Hairline stainless steel
 Handrail: Stainless steel tube
 Floor: PVC

GRV home elevator

Sicher GRV home elevator which is designed for private residence is committed to create a comfortable private space for family, and enhancing the quality of the life. It combines with quiet and comfortable, safe and reliable, protects environmental and saves energy, customized and easy installation and some other advantages, which give more value to private residence.

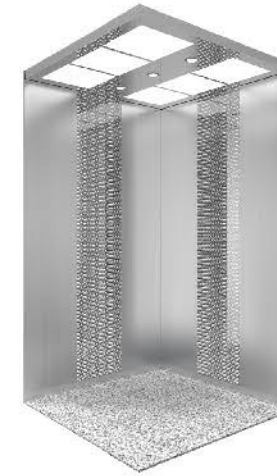

RHX01 (Optional)
 Car wall: Hairline stainless steel plate, mirror etching
 Ceiling: RHT10 Mirror stainless steel plate, acrylic light, downlight illumination
 Floor: RHD06 (PVC)



RHX02 (Optional)
 Rear wall: Stainless steel + lower glass (frosted glass) + upper glass (frosted glass)
 Side wall: Stainless steel + lower glass (frosted glass) + upper glass (specular glass)
 Front wall: Hairline stainless steel
 Car door: Hairline stainless steel
 Ceiling: RHT04 Mirror stainless steel frame, downlight illumination on both sides
 Handrail: Hairline stainless steel (RF001), single on rear wall
 Floor: RHD05 (PVC)



RHX03 (Optional)
 Rear wall: Bronze mirror stainless steel on two sides, bronze mirror etched stainless steel in the middle, marble escutcheon
 Side wall: Bronze mirror stainless steel on two sides, wood trim in the middle, hairline trim, marble escutcheon
 Front wall: Bronze mirror stainless steel
 Car door: Stainless steel coated with bronze
 Lintel beam: Stainless steel coated with bronze
 Ceiling: RHT07 Titanium stainless steel frame, transparent acrylic board in the middle, downlights on two sides, ring light in the middle
 Handrail: Solid wood (RF009), single on rear wall
 Floor: RHD13 (PVC)



RHX04 (Optional)
 Rear wall: Etched mirror stainless steel coated with bronze, 10mm mirror decoration strip, etched mirror stainless steel coated with black
 Side wall: Etched mirror stainless steel coated with bronze, 10mm mirror decoration strip
 Front wall: Mirror stainless steel coated with black
 Car door: Mirror stainless steel
 Transom: Mirror stainless steel coated with black
 Ceiling: RHT08 Mirror stainless steel coated with black, yellow acrylic transparent board
 Handrail: Solid wood (RF009), single on rear wall
 Floor: RHD14 (PVC)



RHX05 (Optional)
 Rear wall: Sand blasting stainless steel coated with bronze, etched stainless steel
 Side wall: Sand blasting stainless steel coated with bronze, mirror stainless steel
 Front wall: Sand blasting stainless steel coated with bronze
 Car door: Sand blasting stainless steel coated with bronze
 Transom: Mirror stainless steel coated with black
 Ceiling: RHT06 stainless steel coated with bronze, downlight (LED)
 Handrail: RF008 (stainless steel coated with bronze) single on rear wall
 Floor: RHD12 (PVC)



RHX06 (Standard)
 Car wall: Hairline stainless steel plate
 Ceiling: RHT04 Mirror stainless steel frame, downlight illumination on both sides
 Floor: RHD01 (PVC)

Home elevator landing door series



RHM08 (Standard)



RHM09 (Optional)



RHM10 (Optional)



RHM11 (Optional)



Three-dimensional parking system An effective solution plan to solve the difficult parking in modern cities

Following the progressive increase of private cars each year, apart from crowded modern traffic, it has the problem of difficult parking. Sicer Elevator puts out a series of mechanical parking system to solve the problem according to the market requirements. It fulfills more and more utilization values of city space. It relieves difficult parking to the greatest extent.

GRB bed elevator

Based on the full consideration to the special requirements of medical institution, GRB series bed elevator realizes the convenience transport of hospital beds, medical workers and some other medical equipment with optimized car structure. Its precise running speed control makes patients and workers feel comfortable and stable; It is also fully considered on every details about hall call box, handrail, etc., to show the humanistic care.

GRE escalator GRM moving walk

With incorporation of the well-developed escalator and moving walk technology, advanced micro-computer control system, high strength truss structure, classical driving system, and completed safety devices, GRE / GRM of escalators and moving walks fully ensure our products safe, reliable, endurable and bring steady and comfortable riding. Complying with national standard GB16899 and European standard EN115, the escalator and moving walk are applicable for heavy-passenger—flow location such as market, supermarket, hotel, subway, airport, trainstation, crossroad and public buildings.

GRE50 Public transport type escalator

Sicher GRE50 public transport escalator is customized specially for public transport with the maximum lifting height of 30 meters. With excellent quality, powerful performance and advanced security assurance in one, it is able to fully meet stringent carrier requirements in light of height, time and passenger flow, applicable to public transportation area such as subway, railway stations, airports and others.

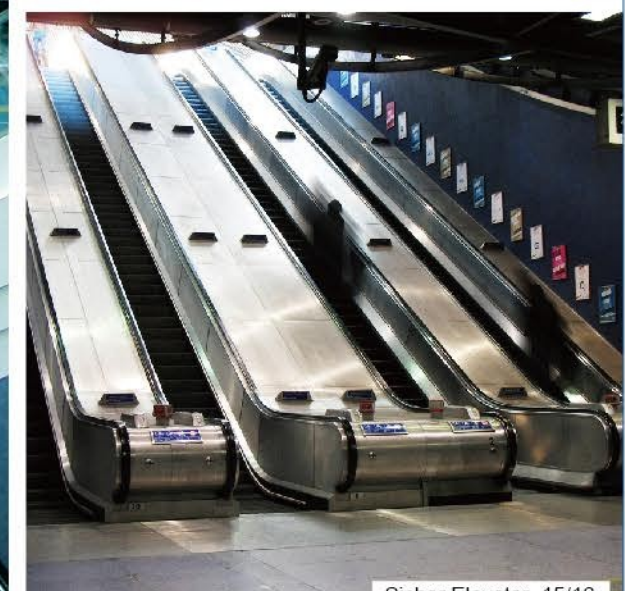
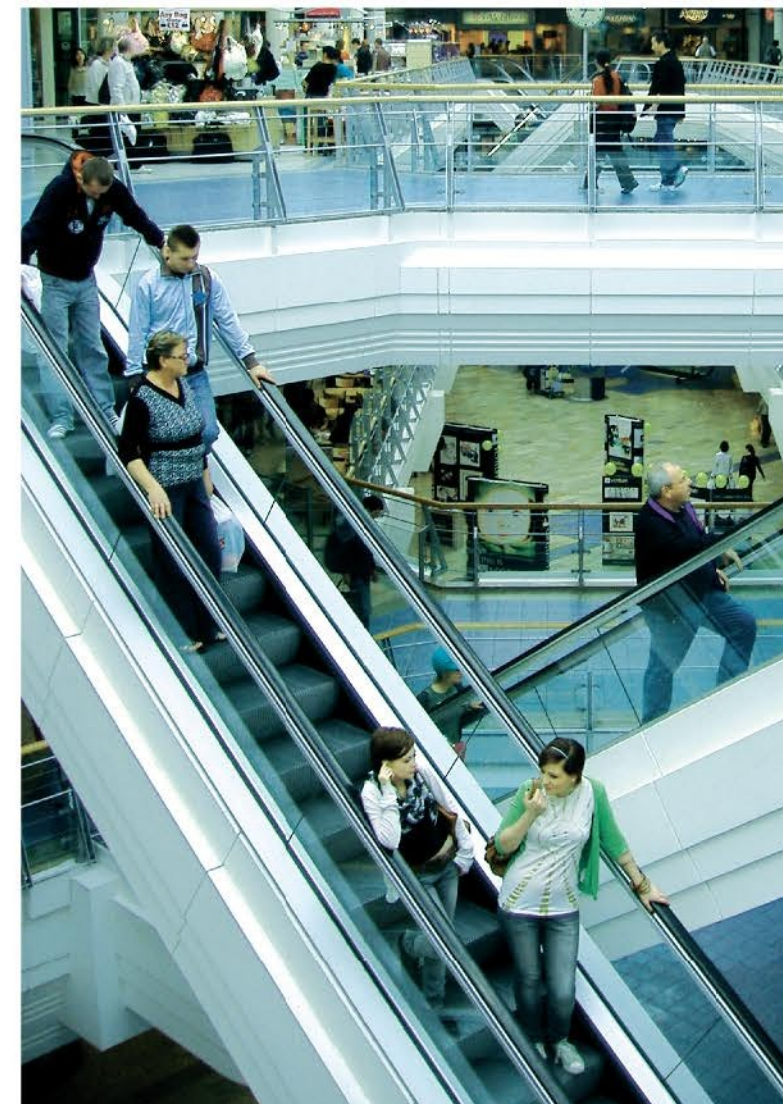



GRF freight elevator

GRF series freight elevators, employing the fully PC controlling technology, AC variable frequency and variable voltage VVVF, has not only the outstanding performance in energy saving and precision of leveling and highly effective load capacity, but also take the user's requirements into full consideration when designing. As a result, the performance/price ratio of these elevators is high and the elevators can be used in vertical transportation occasion such as factories, transportation centers, warehouses and vehicles, vertical transportation.

GRFN machine roomless freight elevator

Machine room-less freight elevator adopts the advanced permanent-magnet synchronous gearless traction technology. Therefore, it is not necessary to use the decelerating device, which improves the arrangement inside the hoist-way. The gearless machine are featured in the light weight and small size, which saves the space of the construction, greatly improves the performance and quality of the machine room-less freight elevator and reduces the fault rate.

GRFH serial hydraulic freight elevator

GRFH serial hydraulic freight elevator is of the consummate technology superb skill. It is suitable for the hydraulic elevators with different capacity. It has advantageous start, brake and leveling results. It can automatically produce the good travel curve and the travel comfort.

GRA car elevator

GRA car elevator utilizes new data processing network. Landings and cabin of GRA10 car elevator are allocated with computer control system (CPU). They have been connected through serial transmission lines. It reduces the connecting lines amid various parts and results in more efficient and precise system control. The diagnosis program and backup system amid various computers ensure the high reliability of the parts connection. Each computer specially sets the software with the reasoning ability. It enriches and perfects man (car) – elevator interface.

We utilize the advanced and large-scale programmable gate array into the car elevators. We fulfill the monolithic integration of the system, effectively enhance the anti-interference of the system with the more simple operation and the more sensitive reaction.

GRAH hydraulic car elevator

GRAH serial hydraulic car elevators use Italian GMV hydraulic system with a combination of the mature and reliable PC control technology. Apart from all the safety protection devices of traction type elevators, we additionally add the multiple hydraulic circuit protection systems such as safety valve, speed limit disconnecting valve etc. to ensure the standard of travel quality and security.

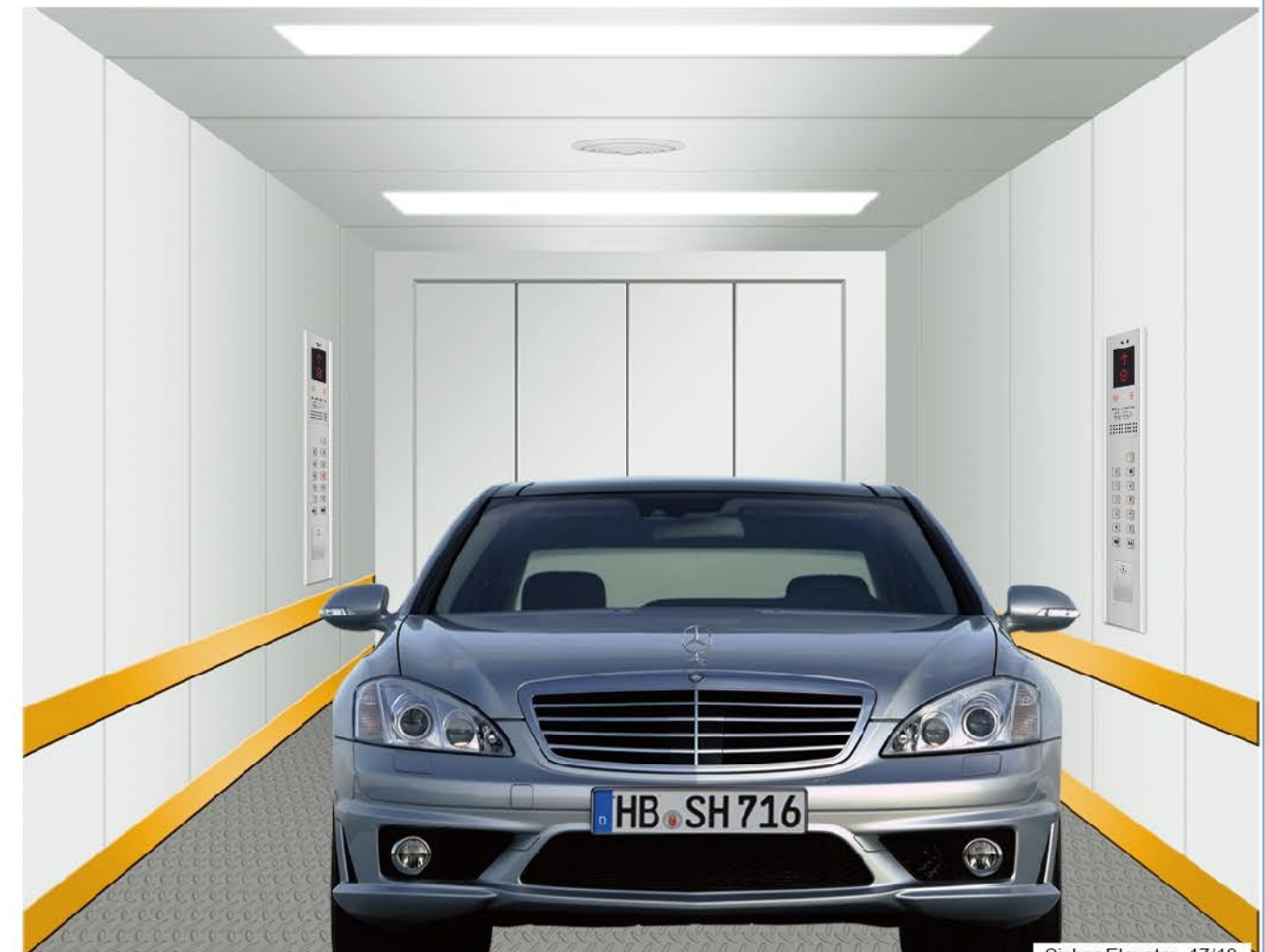

Car decoration



RJ011 (Standard)

Car wall: Hairline stainless steel
Car door: Hairline stainless steel
Ceiling: Mirror stainless steel, LED crystal lamp (RD014)
Floor: PVC (RPV010)
Handrail: Stainless steel round pipe (RF002) (Optional)
Operation panel: RC004

RJ013 (Optional)

Rear wall: A combination of hairline stainless steel and mirror etched stainless steel
Side wall: A combination of hairline stainless steel and mirror etched stainless steel
Ceiling: Mirror stainless steel frame, LED crystal light (RD014)
Handrail: Stainless steel round tube (RF002)
Floor: PVC (RPV002)
Operation panel: RC004

RJ011



RJ013

Scan the QR code to know more about the lift car in the 360-degree manner



RJ016 (Standard)

Car wall: Painted steel (RS004)
Car door: Painted steel (RS004)
Ceiling: Painted steel, acrylic lighting decoration, down light (RD042)
Floor: PVC (RPV010)
Operation panel: RC004

RJ018 (Optional)

Rear wall: A combination of hairline stainless steel and gold mirror etched stainless steel
Side wall: A combination of hairline stainless steel and gold mirror etched stainless steel
Ceiling: Hairline stainless steel frame, translucent panels in the middle and down light illumination on both sides (RD006)
Handrail: Stainless steel round tube (RF002)
Floor: PVC (RPV011)
Operation panel: RC009

RJ016



RJ018

Scan the QR code to know more about the lift car in the 360-degree manner



Car decoration



RJ031 (Optional)

Rear wall: A combination of mirror stainless steel and mirror etched stainless steel
Side wall: A combination of mirror stainless steel and mirror etched stainless steel
Ceiling: Mirror stainless steel frame, crystal column in the middle and down light illumination on both sides (RD018)
Floor: PVC (RPV008)
Operation panel: RC009

RJ033 (Optional)

Rear wall: A combination of marble and mirror stainless steel
Side wall: A combination of marble and mirror stainless steel
Ceiling: Painted steel frame, acrylic translucent panels in the middle, down light illumination on both sides (RD016)
Handrail: Titanium on both sides and mirror stainless steel tube
Floor: PVC (RPV011)
Operation panel: RC009

RJ031

Scan the QR code to know more about the lift car in the 360-degree manner

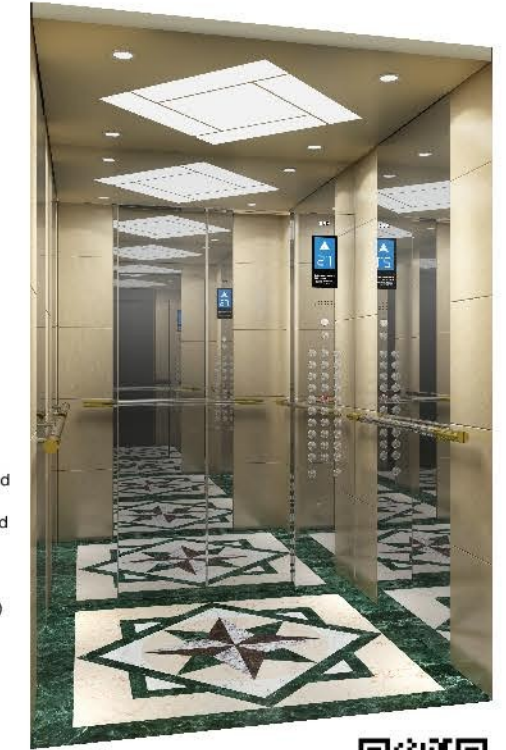

RJ033

Scan the QR code to know more about the lift car in the 360-degree manner



RJ034 (Optional)

Rear wall: A combination of titanium gold stainless steel and titanium gold mirror etched stainless steel
Side wall: A combination of titanium gold mirror stainless steel and mirror stainless steel
Ceiling: Titanium gold mirror stainless steel frame, combination of middle lamp belt lighting and titanium mirror etched stainless steel, down light illumination at two sides
Handrail: Titanium gold stainless steel round tube (RF003)
Floor: PVC (RPV034)
Operation panel: RC009

RJ035 (Optional)

Rear wall: A combination of mirror stainless steel and wood-grain car wall
Side wall: A combination of mirror stainless steel and wood-grain car wall
Ceiling: Mirror stainless steel frame, translucent panels in the middle and down light illumination on both sides
Handrail: Combination of mirror stainless steel and wooden double tubes
Floor: PVC (RPV012)
Operation panel: RC009

RJ034

Scan the QR code to know more about the lift car in the 360-degree manner

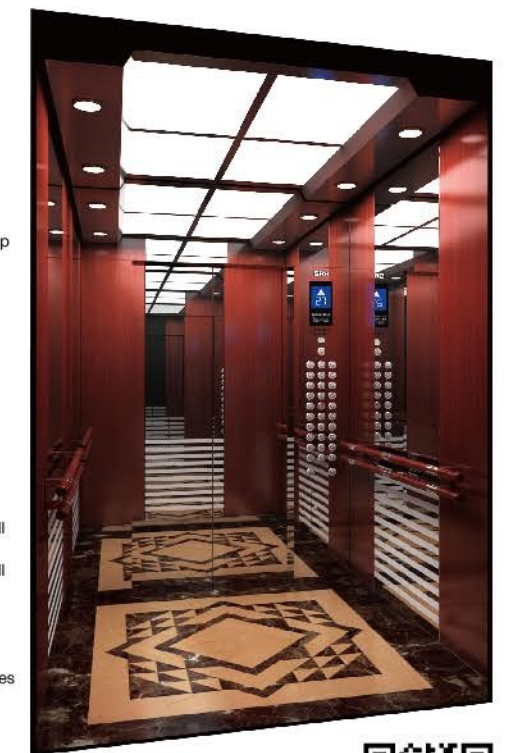

RJ035

Scan the QR code to know more about the lift car in the 360-degree manner



Car decoration



RJ041 (Optional)

Rear wall: Titanium gold mirror etched stainless steel in the middle, titanium gold mirror stainless steel at both sides
Side wall: Wood finishing inlaid with metal strip at both sides, leather finishing in the middle
Ceiling: Titanium gold mirror stainless steel frame, translucent acrylic panel in the middle, LED down light at two sides
Handrail: Wood finishing in the middle, titanium gold at two ends (RF007)
Floor: PVC(RPV041)
Operation panel: RC009

RJ042 (Optional)

Rear wall: Rose gold etched stainless steel with craft wooden frame and rose gold mirror stainless steel
Side wall: Leather wrapped with rose gold mirror stainless steel
Ceiling: Rose gold mirror stainless steel, hidden lights and LED down light illumination
Handrail: Brushed stainless steel (RF005)
Floor: PVC(RPV042)
Operation panel: RC009



RJ042

Scan the QR code to know more about the lift car in the 360-degree manner



RJ041

Scan the QR code to know more about the lift car in the 360-degree manner

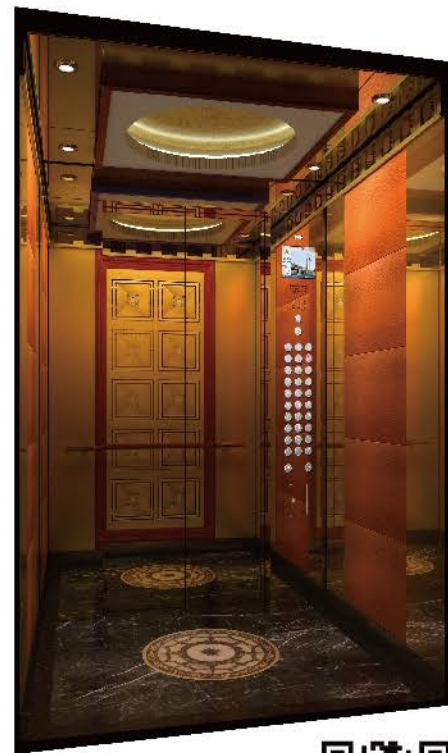

RJ043 (Optional)

Rear wall: Titanium gold mirror stainless steel at two sides, titanium gold etched stainless steel in the middle with wood finishing frame
Side wall: Titanium gold mirror stainless steel at two sides, leather wrapped in the middle
Ceiling: Titanium gold stainless steel frame, light strip illumination in the middle with wood finishing frame, down light illumination at two sides
Handrail: Wood finishing in the middle, titanium gold at two ends(RF007)
Floor: PVC(RPV043)
Operation panel: RC009

RJ045 (Optional)

Rear wall: A combination of hairline stainless steel and mirror etched stainless steel
Side wall: A combination of hairline stainless steel and mirror etched stainless steel
Ceiling: Mirror stainless steel frame, down light illumination at two sides (RD015)
Handrail: Hairline stainless steel (RF005)
Floor: PVC (RPV011)
Operation panel: RC004



RJ045

Scan the QR code to know more about the lift car in the 360-degree manner



RJ043

Scan the QR code to know more about the lift car in the 360-degree manner



Human-machine interface

RC004 (Standard)

Panel material: Hairline stainless steel
Display screen: Dot matrix display screen

Button: Round micro-stroke button
Parking number: 2~36 parking floors

• Display screen



Dot matrix display
Standard



Single-color LCD
Optional



Pure display color LCD
Optional



Picture type display
Optional



Video type display
Optional

• Button



Round button
Standard

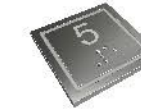

Square button
Optional

• Panel material



Hairline stainless steel
Standard



Mirror stainless steel
Optional



Titanium gold hairline stainless steel
Optional



Titanium gold mirror stainless steel
Optional

• Hall call box (no bottom box) (Standard)



RZ004-1-3
Simplex



RZ004-1-4
Duplex

• Hall call box (Optional)



RZ004-1-1
Simplex



RZ004-1-2
Duplex



RC004

Human-machine interface

RC009 (Optional)

Panel material: Hairline stainless steel
Display screen: Single-color LCD

Button: Round micro-stroke button
Parking number: 2~48 parking floors



RC009
Integrated operation panel

• Display screen



Single-color LCD Standard
White character in black LCD Optional
Pure display color LCD Optional
Picture type display Optional
Video type display Optional

• Button



Round button Standard
Square button Optional

• Panel material



Hairline stainless steel Standard
Mirror stainless steel Optional
Titanium gold hairline stainless steel Optional
Titanium gold mirror stainless steel Optional

• Hall call box (no bottom box) (Standard)



RZ004-1-3 Simplex
RZ004-1-4 Duplex

• Hall call box (Optional)



RZ004-1-1 Simplex
RZ004-1-2 Duplex

Human-machine interface

RC011 (Optional)

Panel material: Fingerprint resistant stainless steel
Display screen: Dot matrix display screen

Button: Round micro-stroke button
Parking number: 2~36 parking floors



RC011

• Display screen



Dot matrix display Standard
White character in black LCD Optional
Pure display color LCD Optional

• Button



Round button Optional

• Hall transom indicator



RZ011-1-7

• Panel material

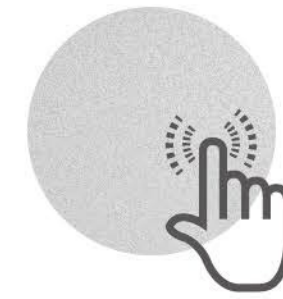

Fingerprint resistant stainless steel

• Hall call box (Standard)



RZ011-1-1 Simplex
RZ011-1-2 Duplex

• Hall call box (no bottom box) (Optional)



RZ011-1-3 Simplex
RZ011-1-4 Duplex

Human-machine interface

RC012 (Optional)

Panel material: Hairline stainless steel
Display screen: Picture type display

Button: Round micro-stroke button
Parking number: 2 ~ 12 parking floors



RC012
Integrated operation panel

• Display screen



Picture type display Standard
Single-color LCD Optional
White character in black LCD Optional
Pure display color LCD Optional
Video type display Optional

• Button



Round button Standard
Square button Optional

• Panel material

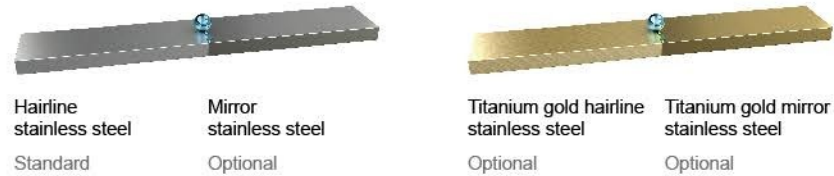

Hairline stainless steel Standard
Mirror stainless steel Optional
Titanium gold hairline stainless steel Optional
Titanium gold mirror stainless steel Optional

• Hall call box (no bottom box) (Standard)



RZ004-1-3 Simplex
RZ004-1-4 Duplex

• Hall call box (Optional)



RZ004-1-1 Simplex
RZ004-1-2 Duplex

Human-machine interface



RC001-1
Operation panel for disabled (Optional)



RC001-2
Wall-mounted operation panel for disabled (Optional)

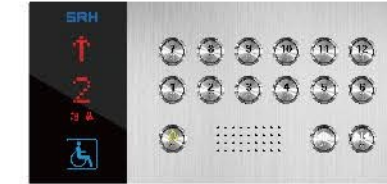

RC001-3
Operation panel for disabled (Optional)

Hall transom indicator



RZ004-1-7



RZ004-1-7A

Landing direction indicator



RZ-1-5A



RZ-1-5B

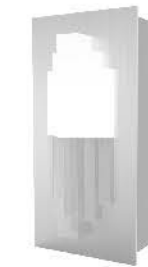

RZ-1-5C



RZ-1-5D

Handrail

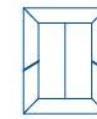

RF001



RF002



RF003



RF004



RF005



RF007

Classical decoration

Ceiling



RD006 (Optional)

Hairline stainless steel frame, translucent panels in the middle and down light illumination on both sides.



RD011 (Optional)

Mirror stainless steel frame, translucent acrylic panel, middle down light illumination.



RD014 (Optional)

Mirror stainless steel frame, LED crystal light.



RD015 (Optional)

Mirror stainless steel frame, acrylic translucent panels in the middle and down light illumination on both sides.



RD017 (Optional)

Painted steel frame, crystal light.



RD018 (Optional)

Mirror stainless steel frame, crystal column in the middle and down light illumination on both sides.



RD045 (Optional)

Hairline stainless steel, LED square lamp, down light.



RD046 (Optional)

Hairline stainless steel, down light.



Landing door

RT011 (Standard)

Landing Door	Hairline stainless steel
Jamb	Hairline stainless steel (narrow type)

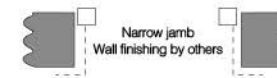

RT012 (Standard)

Landing Door	Painted steel plate (RS004)
Jamb	Painted steel plate (RS004) (narrow type)

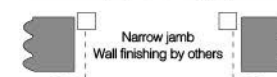

RT101 (Optional)

Landing Door	Hairline stainless steel on two ends + safety glass
Jamb	Hairline stainless steel (straight wall cover)

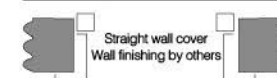

RT014 (Optional)

Landing Door	Etched stainless steel
Jamb	Hairline stainless steel (straight wall cover)

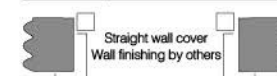

RT015 (Optional)

Landing Door	Etched stainless steel
Jamb	Hairline stainless steel (slant wall cover)

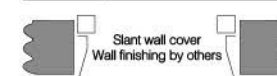

RT016 (Optional)

Landing Door	Mirror Ti-gold etched St.St
Jamb	Mirror Ti-gold St.St (slant wall cover)

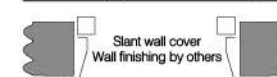

 Floor



RPV002



RPV004



RPV008



RPV010



RPV011



RPV012

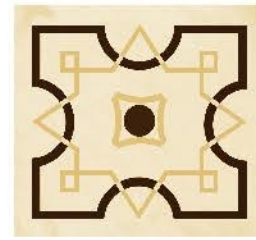

RPV013



RPV014

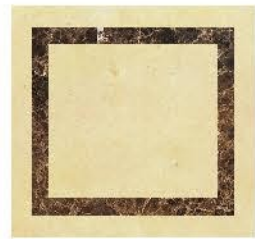

RPV015



RPV016

 Color



RS004



RS001



RS003



RS002



RS006



RS005



RS007



RS008

GRPS20 Small machine room elevator construction sketch

Hoistway elevation

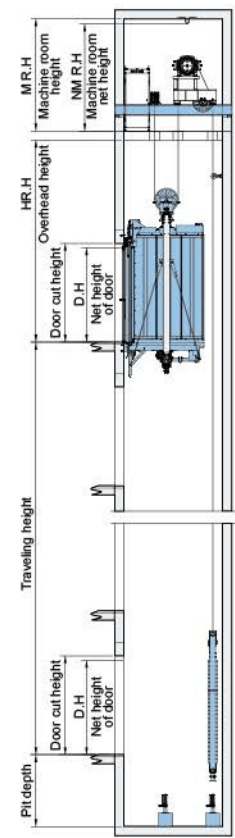

Machine room plan

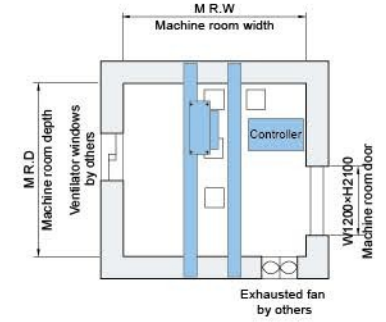

Hoistway plan

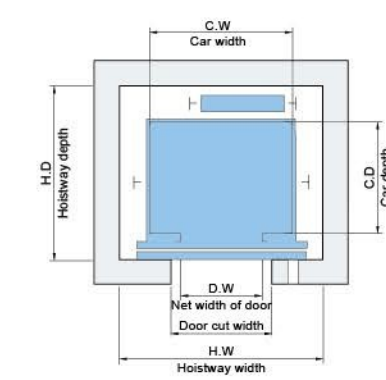

GRPS20 small machine room elevator specifications

Persons	Rated capacity (kg)	Rated speed (m/s)	Net size of car (mm)		Net size of door D.WxD.H (mm)			Hoistway size (mm)			Machine room size (mm)		Max traveling height (m)	
			C.W x C.D	2P Central opening	H.W x H.D	O.H	P.D	M.R.W x M.R.D	M.R.H					
8	830	1.0	1400x1100	800x2100	2000x1750	4100	1350	2000x1750	2300	45				
		1.75									4300	1500	95	
10	800	1.0	1400x1350	800x2100	2000x2000	4100	1350	2000x2000	2300	45				
		1.75									4300	1500	95	
		2.0									4400	1600	120	
		2.5									4700	1700	150	
		3.0									5000	2200	150	
		4.0									5400	2700	180	
13	1000	1.0	1800x1500	900x2100	2200x2150	4100	1350	2200x2150	2300	45				
		1.75									4300	1500	95	
		2.0									4400	1600	120	
		2.5									4700	1700	150	
		3.0									5000	2200	150	
		3.5									5400	2700	180	
		4.0	5800	3200	180									
		1.0	* 1100x2100	900x2100	* 2100x2500	2100x2500	4100	1350	* 2100x2500	2300	45			
		1.75										4300	1500	95
		2.0										4400	1600	120
		2.5										4700	1700	150
		3.0										5000	2200	150
3.5	5400	2700										180		
4.0	5800	3200	180											
15	1150	1.0	1700x1500	1000x2100	2300x2150	4200	1350	2300x2150	2300	45				
		1.75									4300	1500	95	
		2.0									4400	1600	120	
		2.5									4700	1700	150	
		3.0									5000	2200	150	
		3.5									5400	2700	180	
4.0	5800	3200	180											
16	1250	1.0	1950x1400	1100x2100	2800x2050	4200	1350	2600x2050	2300	45				
		1.75									4300	1500	95	
		2.0									4400	1600	120	
		2.5									4700	1700	150	
		3.0									5000	2200	150	
		3.5									5400	2700	180	
4.0	5800	3200	180											
18	1350	1.0	1950x1550	1100x2100	2800x2200	4200	1350	2600x2200	2300	45				
		1.75									4300	1500	95	
		2.0									4400	1600	120	
		2.5									4700	1700	150	
		3.0									5000	2200	150	
		3.5									5400	2700	180	
4.0	5800	3200	180											
21	1800	1.0	1950x1750	1100x2100	2800x2400	4200	1350	2600x2400	2300	45				
		1.75									4300	1500	95	
		2.0									4400	1600	120	
		2.5									4700	1700	150	
		3.0									5000	2200	150	
		3.5									5400	2700	180	
4.0	5800	3200	180											
28	2000	1.0	2100x1950	1200x2100	2800x2600	4200	1350	2800x2600	2300	45				
		1.75									4300	1500	95	
		2.0									4400	1600	120	
		2.5									4700	1700	150	
		3.0									5000	2200	150	
		3.5									5400	2700	180	
4.0	5800	3200	180											

*For stretcher elevator

GRPN20 machine roomless elevator construction sketch

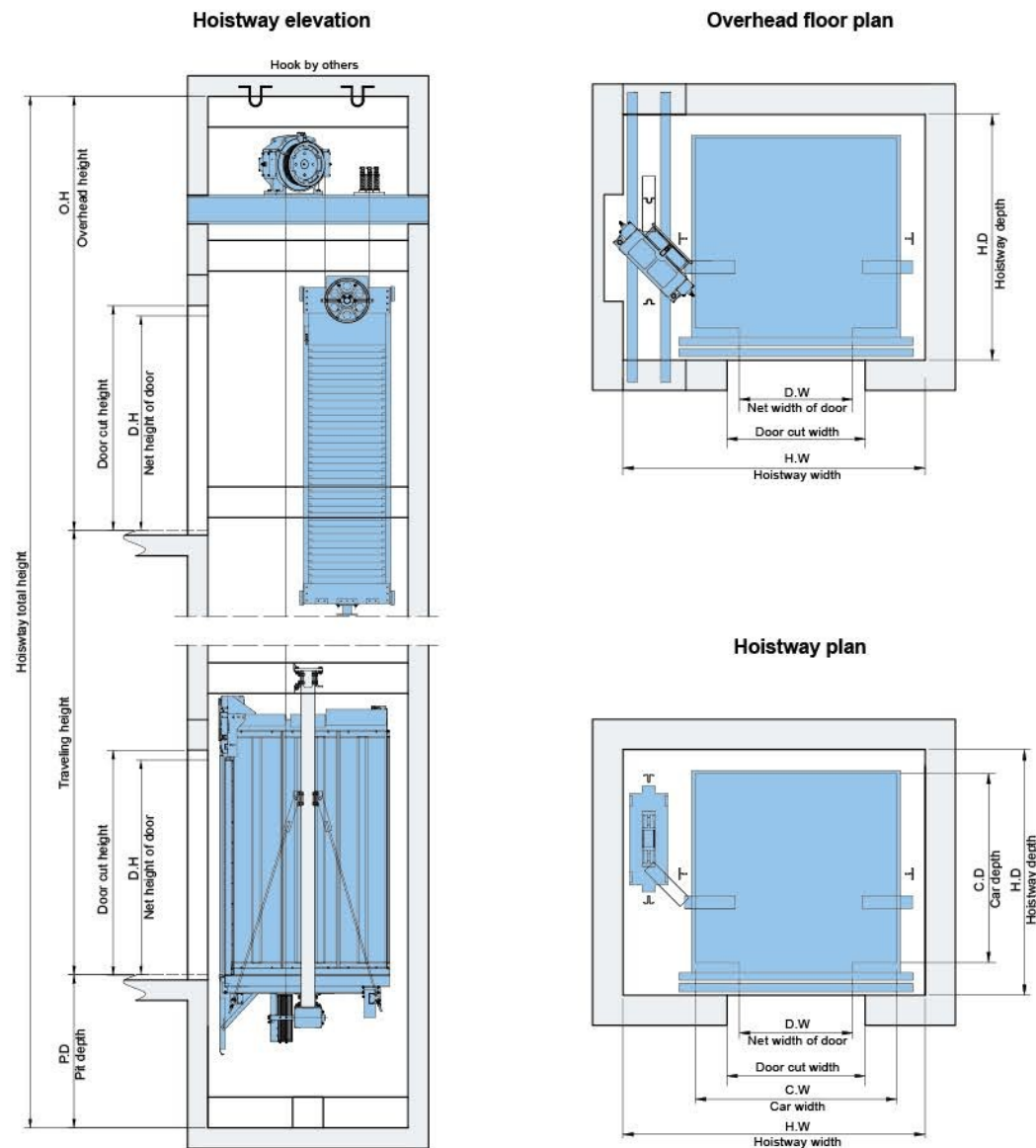

GRPS30 rear counterweight construction sketch

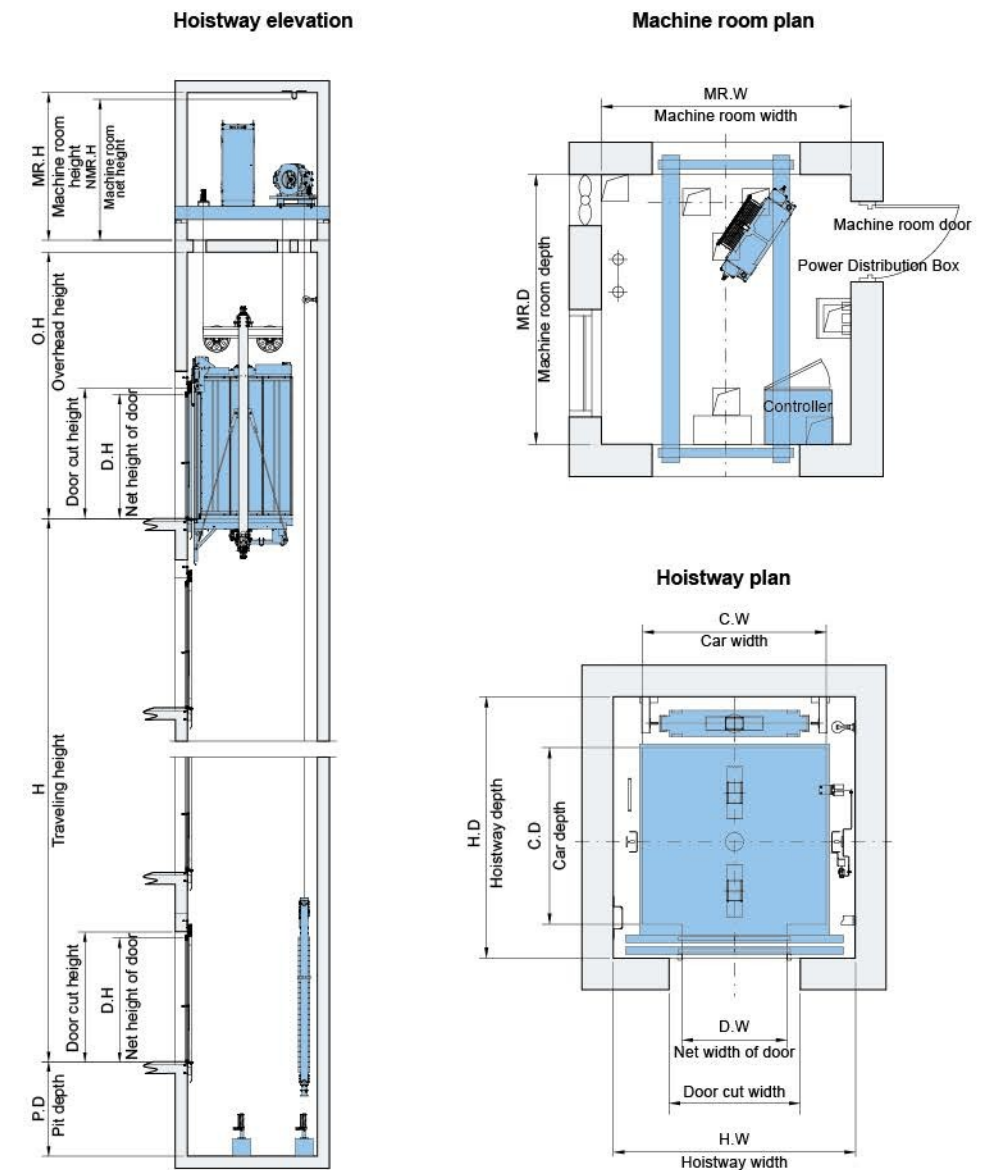

GRPN20 machine roomless elevator specifications

Persons	Rated capacity (kg)	Rated speed (m/s)	Net size of car (mm)		Net size of door D.WxD.H (mm)			Hoistway size (mm)			Max traveling height (m)		
			C.W x C.D	2P Central opening	H.W x H.D	O.H	P.D	H.W	O.H	P.D			
8	630	1.0	1400x1100	800x2100	2200x1700	4000	1600	45	1600	1600	45		
		1.75										4100	60
		2.0										4200	75
10	800	1.0	1400x1350	800x2100	2200x1850	4000	1600	45	1600	1600	45		
		1.75										4100	60
		2.0										4200	75
13	1000	1.0	1600x1500	900x2100	2400x1950	4000	1600	45	1600	1600	45		
		1.75										4100	60
		2.0										4200	75
16	1250	1.0	1950x1400	1100x2100	2950x1850	4300	1600	45	1600	1600	45		
		1.75										4400	60
		2.0										4500	75
18	1350	1.0	1950x1550	1100x2100	2950x2000	4300	1600	45	1600	1600	45		
		1.75										4400	60
		2.0										4500	75
21	1600	1.0	1950x1750	1100x2100	2950x2200	4500	1600	45	1600	1600	45		
		1.75										4600	60
		2.0										4700	75

GRPS30 rear counterweight specifications

Persons	Rated capacity (kg)	Rated speed (m/s)	Net size of car (mm)		Net size of door (mm) D.WxD.H		Hoistway size (mm)			Machine room size (mm)			
			C.W x C.D	2P Central opening	H.W x H.D	O.H	P.D	MR.W x MR.D	MR.H				
8	630	1.0	1400x1100	800x2100	800x2100	1850x1750	4000	1350	1850x1750	2300	2300		
		1.75										4100	1450
		2.0										4200	1500
10	800	1.0	1400x1350	800x2100	800x2100	1850x2000	4000	1350	1850x2000	2300	2300		
		1.75										4100	1450
		2.0										4200	1500
13	1000	1.0	1600x1400	900x2100	900x2100	2050x2050	4000	1350	2050x2050	2300	2300		
		1.75										4100	1450
		2.0										4200	1500
		1.0	*1100x2100	*2100x2500	*2100x2500	*2100x2500	*4100	*1350	*2100x2500	2300	2300		
		1.75										*4300	*1500
		2.0										*4400	*1600
14	1050	1.0	1600x1500	900x2100	900x2100	2050x2150	4000	1350	2050x2150	2300	2300		
		1.75										4100	1450
		2.0										4200	1500
18	1350	1.0	1950x1550	1100x2100	1100x2100	2500x2200	4200	1350	2500x2200	2500	2500		
		1.75										4400	1500
		2.0										4500	1600
21	1600	1.0	1950x1750	1100x2100	1100x2100	2500x2400	4200	1350	2500x2400	2500	2500		
		1.75										4400	1500
		2.0										4500	1600

*For stretcher elevator

GRPS50 side counterweight construction sketch

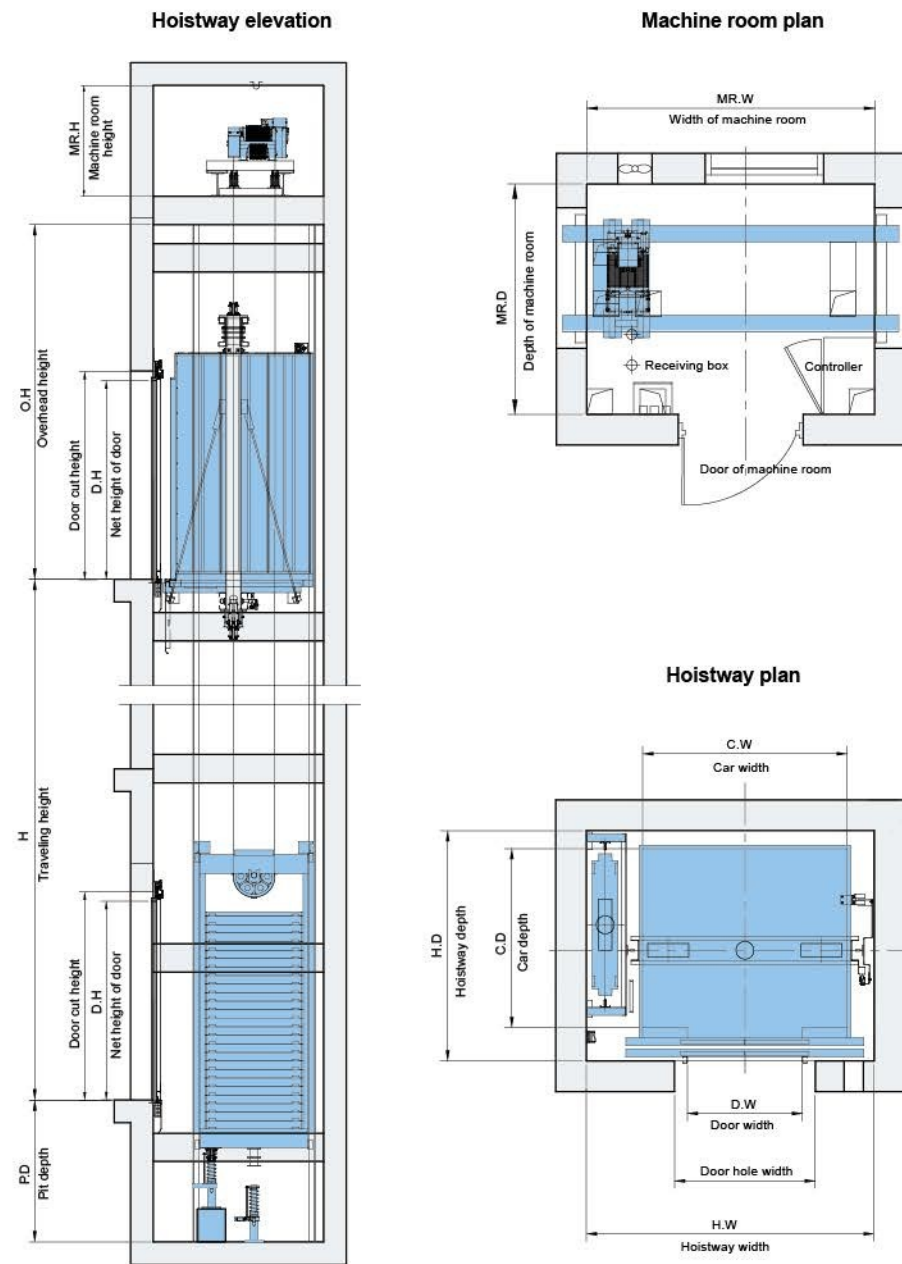

GRPS50 side counterweight specifications

Persons	Rated capacity (kg)	Rated speed (m/s)	Net size of car (mm)		Hoistway size (mm)			Machine room size (mm)	
			C.W X C.D	2P Central opening	H.W X H.D	O.H	P.D	MR.W X MR.D	MR.H
8	630	1.0	1100x1400	800x2100	1800x1800	3800	1350	1800x1800	2300
		1.5				3900	1450		
		1.6				4000	1500		
		1.75				3800	1350		
		2.0				3900	1450		
10	800	1.0	1350x1400	800x2100	2000x1800	3900	1450	2000x1800	2300
		1.5				4000	1500		
		1.6				3800	1350		
		1.75				3900	1450		
		2.0				4000	1500		
13	1000	1.0	1600x1400	900x2100	2250x1800	3900	1450	2250x1800	2300
		1.5				4000	1500		
		1.6				3800	1350		
		1.75				3900	1450		
		2.0				4000	1500		
14	1050	1.0	1600x1500	900x2100	2250x1900	3900	1450	2250x1900	2300
		1.5				4000	1500		
		1.6				3800	1350		
		1.75				3900	1450		
		2.0				4000	1500		
13	1000	1.0	*1100x2100	900x2100	*2000x2500	3900	1450	*2000x2500	2300
		1.5				4000	1500		
		1.6				3800	1350		
		1.75				3900	1450		
		2.0				4000	1500		

* For stretcher elevator

GRPS50 rear counterweight construction sketch

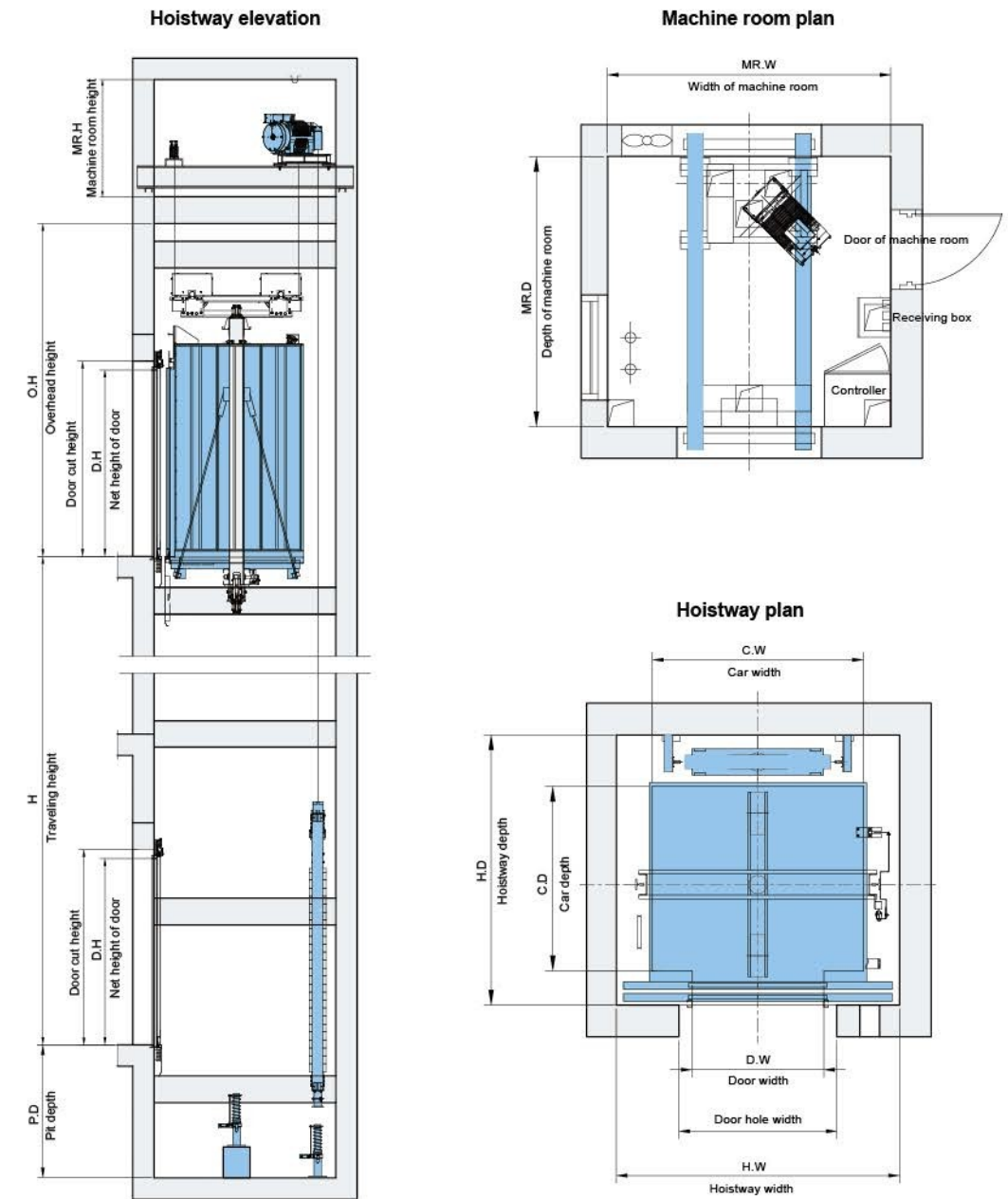

GRPS50 rear counterweight specifications

Persons	Rated capacity (kg)	Rated speed (m/s)	Net size of car (mm)		Hoistway size (mm)			Machine room size (mm)	
			C.W X C.D	2P Central opening	H.W X H.D	O.H	P.D	MR.W X MR.D	MR.H
8	630	1.0	1400x1100	800x2100	1850x1750	3800	1350	1850x1750	2300
		1.5				3900	1450		
		1.6				4000	1500		
		1.75				3800	1350		
		2.0				3900	1450		
10	800	1.0	1400x1350	800x2100	1850x2000	3900	1450	1850x2000	2300
		1.5				4000	1500		
		1.6				3800	1350		
		1.75				3900	1450		
		2.0				4000	1500		
13	1000	1.0	1600x1400	900x2100	2050x2050	3900	1450	2050x2050	2300
		1.5				4000	1500		
		1.6				3800	1350		
		1.75				3900	1450		
		2.0				4000	1500		
14	1050	1.0	1600x1500	900x2100	2050x2150	3900	1450	2050x2150	2300
		1.5				4000	1500		
		1.6				3800	1350		
		1.75				3900	1450		
		2.0				4000	1500		

GRPS70 high speed elevator construction sketch

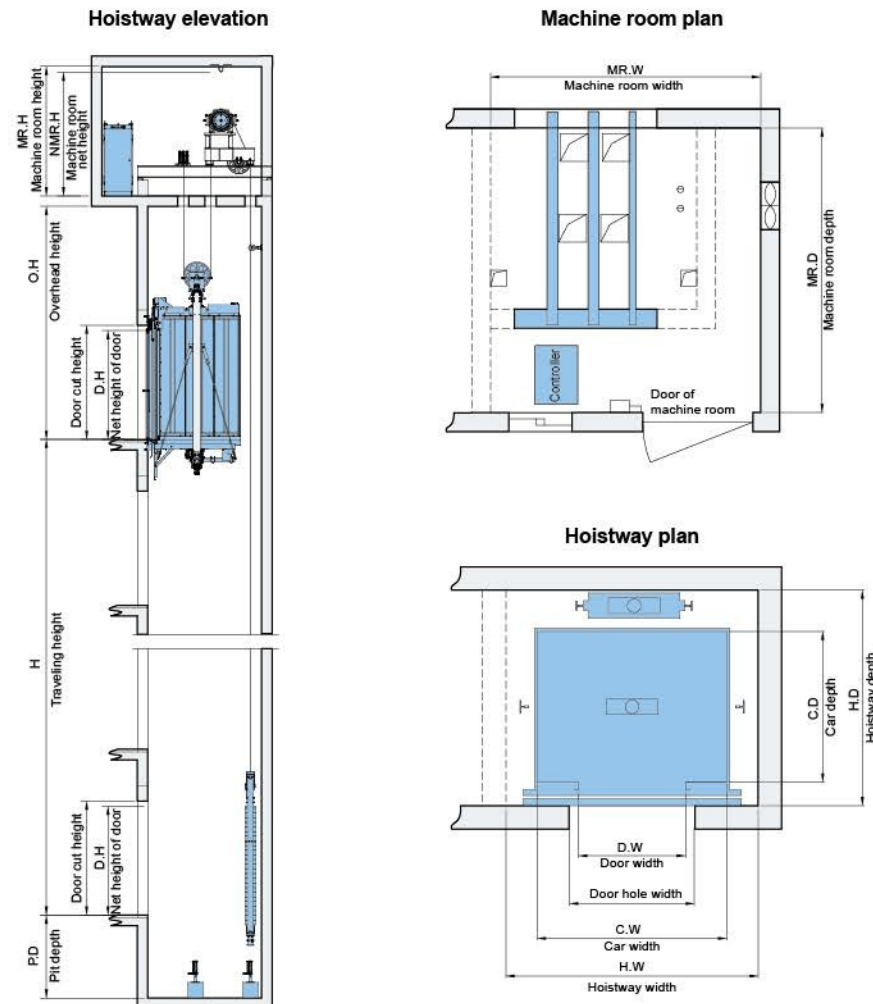

GRPS70 high speed elevator specifications

Persons	Rated capacity (kg)	Rated speed (m/s)	Net size of car (mm) D.WxD.H	Net size of door (mm) 2P Central opening	Hoistway size (mm)			Max traveling height (m)
					C.W x C.D x C.H	H.W x H.D	O.H	
13	1000	4.5	1600x1500x2350	900x2200	2400x2300	5800	3600	220
		5.0				5900	3900	245
		5.5				6000	4200	270
		6.0				6100	4500	290
		6.5				6200	4800	320
		7.0				6300	5100	350
15	1150	4.5	1700x1500x2350	1000x2200	2500x2300	5800	3600	220
		5.0				5900	3900	245
		5.5				6000	4200	270
		6.0				6100	4500	290
		6.5				6200	4800	320
		7.0				6300	5100	350
16	1250	4.5	1950x1400x2350	1100x2200	2750x2200	5800	3600	220
		5.0				5900	3900	245
		5.5				6000	4200	270
		6.0				6100	4500	290
		6.5				6200	4800	320
		7.0				6300	5100	350
18	1350	4.5	1950x1550x2350	1100x2200	2750x2350	5800	3600	220
		5.0				5900	3900	245
		5.5				6000	4200	270
		6.0				6100	4500	290
		6.5				6200	4800	320
		7.0				6300	5100	350
21	1600	4.5	1950x1750x2350	1100x2200	2750x2550	5800	3600	220
		5.0				5900	3900	245
		5.5				6000	4200	270
		6.0				6100	4500	290
		6.5				6200	4800	320
		7.0				6300	5100	350

GROS observation elevator construction sketch

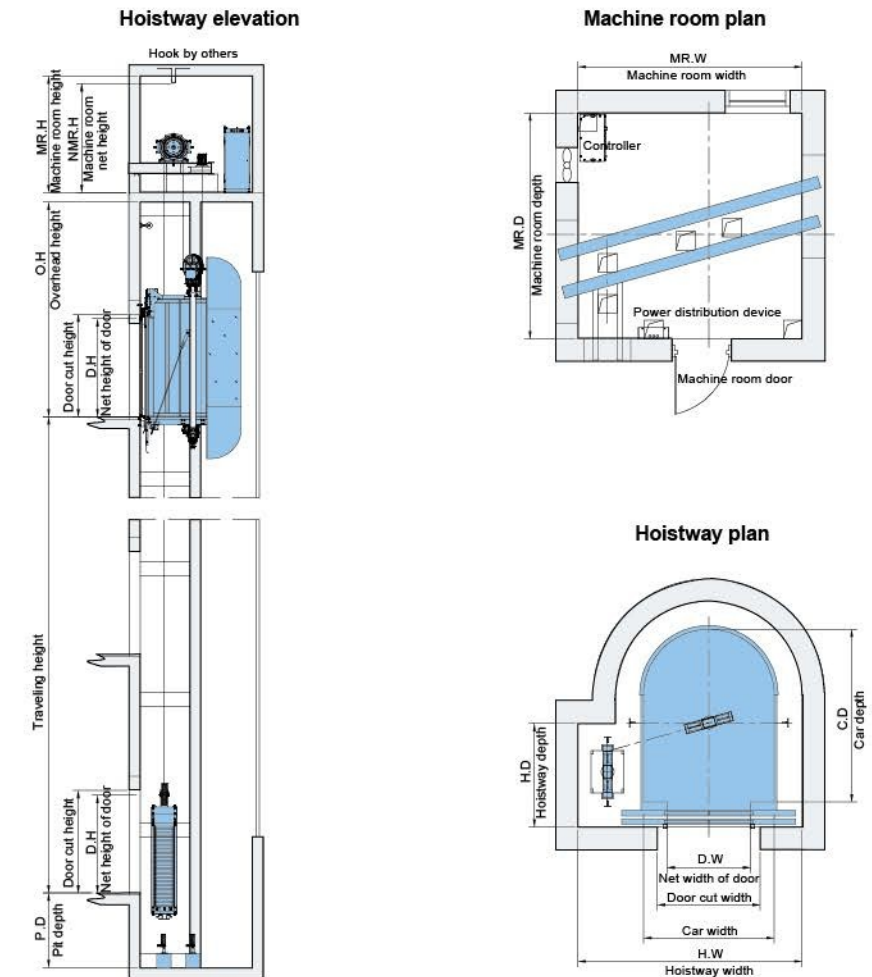

Note: the conceptual diagram takes the horse-hoof panorama lift as an example.

GROS observation elevator specifications

Persons	Rated capacity (kg)	Rated speed (m/s)	Net size of car (mm) C.WxC.D	Net size of door (mm) 2P Center opening	Hoistway size (mm)			Machine room size (mm)		Car shape	Max traveling height (m)
					H.WxH.D	O.H	P.D	MR.WxMR.D	MR.H		
8	630	1.0	1400x1100	800x2100	2200x1650	4100	1400	2200x1650	2500	Square	45
		1.75				4300	1500				95
		2.0				4100	1400				45
10	800	1.75	1400x1350	800x2100	2200x1850	4300	1500	2200x1850	2500	Square	95
		2.0				4400	1600				120
		2.5				4700	1700				150
		1.0				4100	1400				45
		1.75				4300	1500				95
		2.0				4400	1600				120
13	1000	2.0	1600x1500	900x2100	2400x1950	4400	1600	2400x1950	2500	Square	120
		2.5				4700	1700				150
		1.0				4200	1400				45
		1.75				4300	1500				95
		2.0				4400	1600				120
		2.5				4700	1700				150
16	1250	1.0	1950x1400	1100x2100	2750x1900	4200	1400	2750x1900	2500	Square	45
		1.75				4300	1500				95
		2.0				4400	1600				120
		2.5				4700	1700				150
		1.0				4200	1400				45
		1.75				4300	1500				95
18	1350	1.0	1950x1550	1100x2100	2750x2000	4200	1400	2750x2000	2500	Square	45
		1.75				4300	1500				95
		2.0				4400	1600				120
		2.5				4700	1700				150
		1.0				4200	1400				45
		1.75				4300	1500				95
21	1600	1.0	1950x1750	1100x2100	2750x2200	4200	1400	2750x2200	2500	Square	45
		1.75				4300	1500				95
		2.0				4400	1600				120
		2.5				4700	1700				150
		1.0				4200	1400				45
		1.75				4300	1500				95
13	1000	1.0	1400x1850	900x2100	2400x1110	4100	1400	2400x2395	2500	Chamfer	45
		1.75				4300	1500				95
		2.0				4400	1600				120
		2.5				4700	1700				150
		1.0				4100	1400				45
		1.75				4300	1500				95
10	800	1.0	1200x1650	800x2100	2200x1110	4100	1400	2200x2195	2500	Semi-circular shape	45
		1.75				4300	1500				95
		2.0				4400	1600				120
		2.5				4700	1700				150
		1.0				4100	1400				45
		1.75				4300	1500				95
13	1000	1.0	1400x1850	900x2100	2400x1110	4100	1400	2400x2395	2500	Semi-circular shape	45
		1.75				4300	1500				95
		2.0				4400	1600				120
		2.5				4700	1700				150
		1.0				4100	1400				45
		1.75				4300	1500				95
15	1150	1.0	1200x2100	1000x2100	2750x1080	4200	1400	2750x2700	2500	Round	45
		1.75				4300	1500				95
		2.0				4400	1600				120
		2.5				4700	1700				150
		1.0				4200	1400				45
		1.75				4300	1500				95

GRV20 home elevator construction sketch

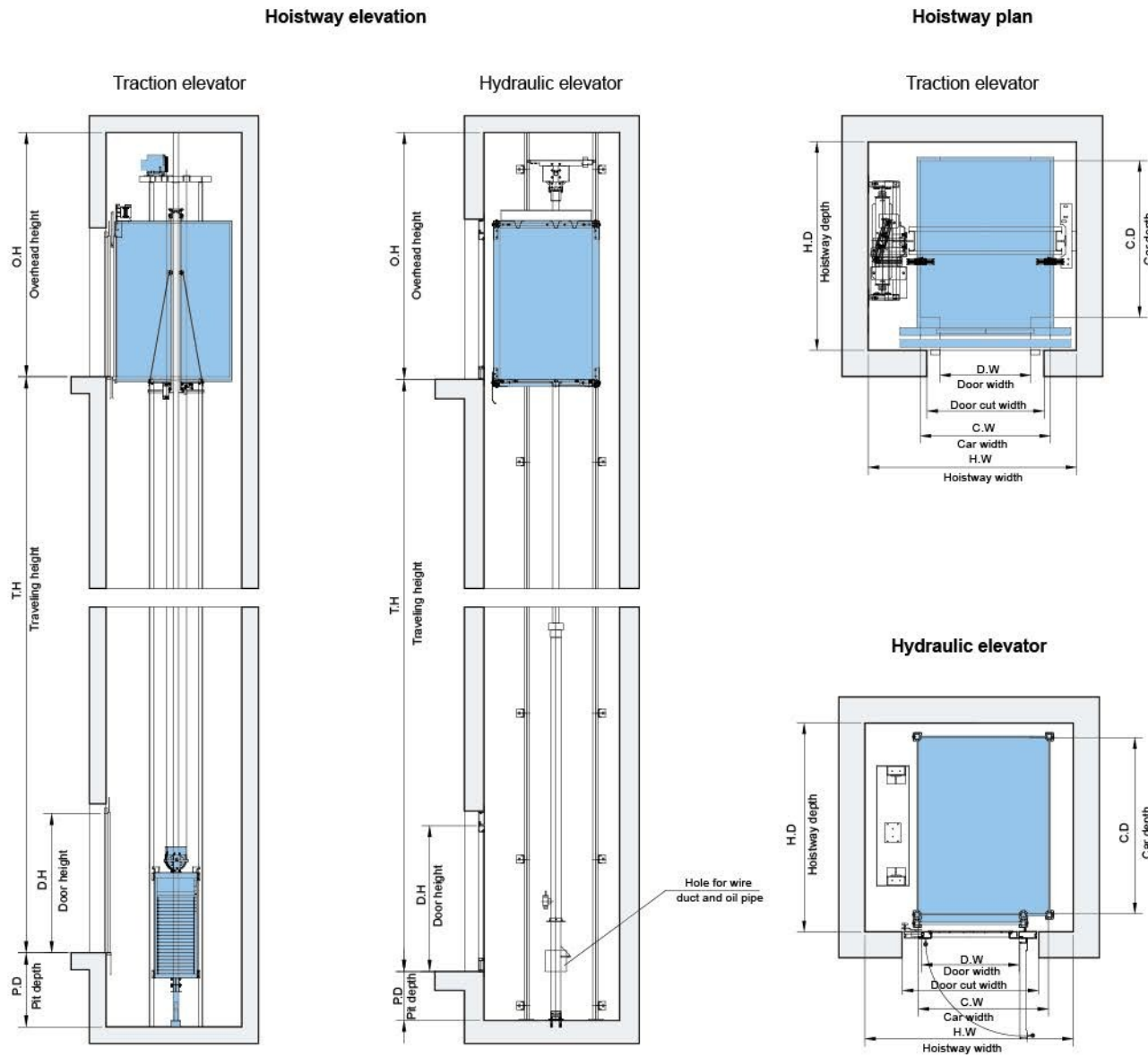

GRV20 home elevator specifications

Drive mode	Traction drive			Hydraulic drive	
	250	320	400	320	400
Load (kg)	250	320	400	320	400
Passenger	3	4	5	4	5
Car width depth (mm) C.W x C.D	800 x 1200	900 x 1200	1000 x 1200	900 x 1200	1000 x 1200
Car height (mm)	2200				
Hoistway width depth (mm) H.W x H.D	1400 x 1800	1500 x 1800	1600 x 1800	1380 x 1450	1480 x 1450
Overhead height (mm) O.H	3000			2900	
Pit depth (mm)	600			300	
Door opening size (mm) (P.L x P.H)	700 x 2000	800 x 2000		750 x 2000	
Door opening mode	Automatic side opening (Automatic center opening)			Hand-pulled outer opening	
Speed (m/s)	0.3 or 0.4			0.22 or 0.28	
Traveling height (mm) O.H	≤ 12m				
Power	220V or 380V				

GRBS bed elevator construction sketch

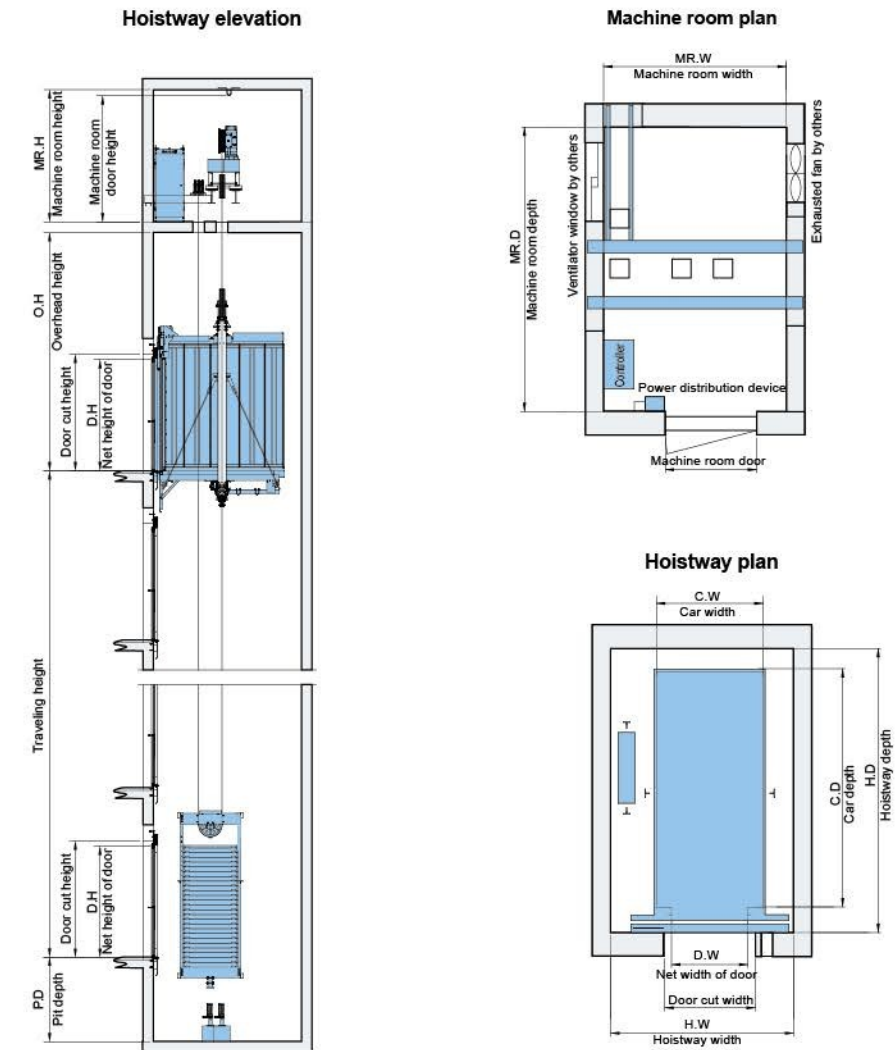

Note: The diagram shows two-panel center door bed lift. Please refer to the construction layout drawing for other detailed specifications of the bed lifts.

GRBS bed elevator specifications

Persons	Rated capacity (kg)	Rated speed (m/s)	Net size of car (mm) C.W x C.D	Net size of door (mm) D.W x D.H	Hoistway size (mm)			Machine room size (mm)		Max traveling height (m)
					H.W x H.D	O.H	P.D	MR.W x MR.D	MR.H	
13	1000	1.0	1100 x 2100	1000 x 2100 2P Central opening	2200 x 2500	2200 x 2500	2500	2500	2500	45
		1.75								95
		2.0								120
		2.5								150
		2.5								150
21	1600	1.0	1400 x 2400	1000 x 2100 2P Central opening	2400 x 2800	2400 x 2800	2500	2500	45	
		1.75							95	
		2.0							120	
		2.5							150	
		2.5							150	
24	1800	1.0	1500 x 2500	1100 x 2100 2P Central opening	2500 x 2900	2500 x 2900	2500	2500	45	
		1.75							95	
		2.0							120	
		2.5							150	
		2.5							150	
26	2000	1.0	1500 x 2700	1200 x 2100 2P Central opening	2600 x 3100	2600 x 3100	2500	2500	45	
		1.75							95	
		2.0							120	
		2.5							150	
		2.5							150	
13	1000	1.0	1100 x 2100	1100 x 2100 2P Telescopic opening	2100 x 2600	2100 x 2600	2500	2500	45	
		1.75							95	
		2.0							120	
		2.5							150	
		2.5							150	
21	1600	1.0	1400 x 2400	1100 x 2100 2P Telescopic opening	2200 x 2900	2200 x 2900	2500	2500	45	
		1.75							95	
		2.0							120	
		2.5							150	
		2.5							150	
24	1800	1.0	1500 x 2500	1200 x 2100 2P Telescopic opening	2300 x 3000	2300 x 3000	2500	2500	45	
		1.75							95	
		2.0							120	
		2.5							150	
		2.5							150	
26	2000	1.0	1500 x 2700	1300 x 2100 2P Telescopic opening	2450 x 3200	2450 x 3200	2500	2500	45	
		1.75							95	
		2.0							120	
		2.5							150	
		2.5							150	

GRPS20F Fireman elevator construction sketch

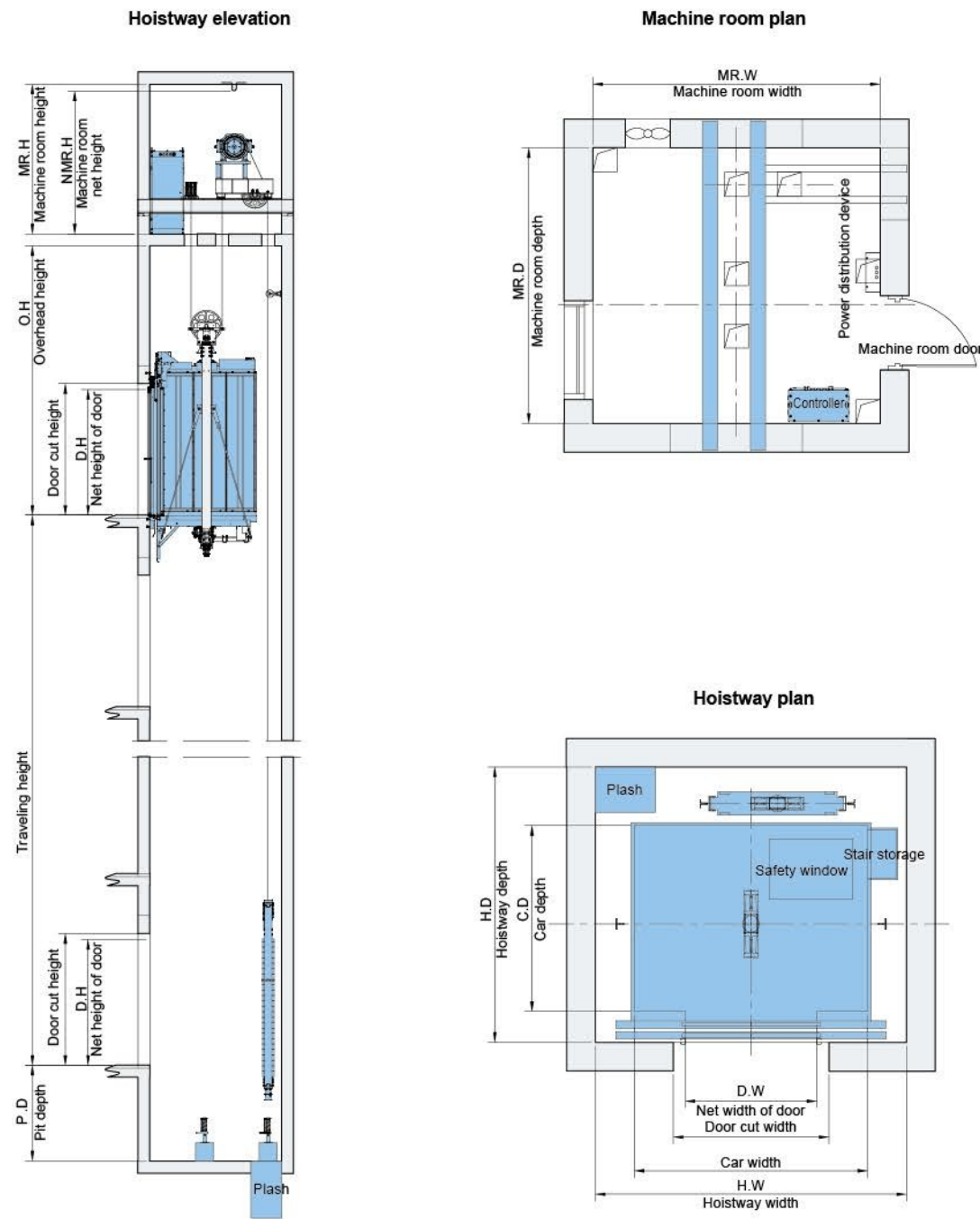

GRPS20F Fireman elevator specifications

Persons	Rated capacity (kg)	Rated speed (m/s)	Net size of car (mm)	Net size of door D.WxD.H (mm)	Hoistway size (mm)			Max traveling height (m)
			C.WxC.D	2P Central opening	H.WxH.D	O.H	P.D	
13	1000	1.0	1800x1500	900x2100	2250x2150	4200	1350	45
		1.75				4300	1500	95
		2.0				4400	1600	120
		2.5				4700	1700	150
		3.0				5000	2200	180
18	1350	1.0	1950x1550	1100x2100	2650x2200	4200	1350	45
		1.75				4300	1500	95
		2.0				4400	1600	120
		2.5				4700	1700	150
		3.0				5000	2200	180
21	1800	1.0	1950x1750	1100x2100	2650x2400	4200	1350	45
		1.75				4300	1500	95
		2.0				4400	1600	120
		2.5				4700	1700	150
		3.0				5000	2200	180

GRF machine room freight elevator construction sketch

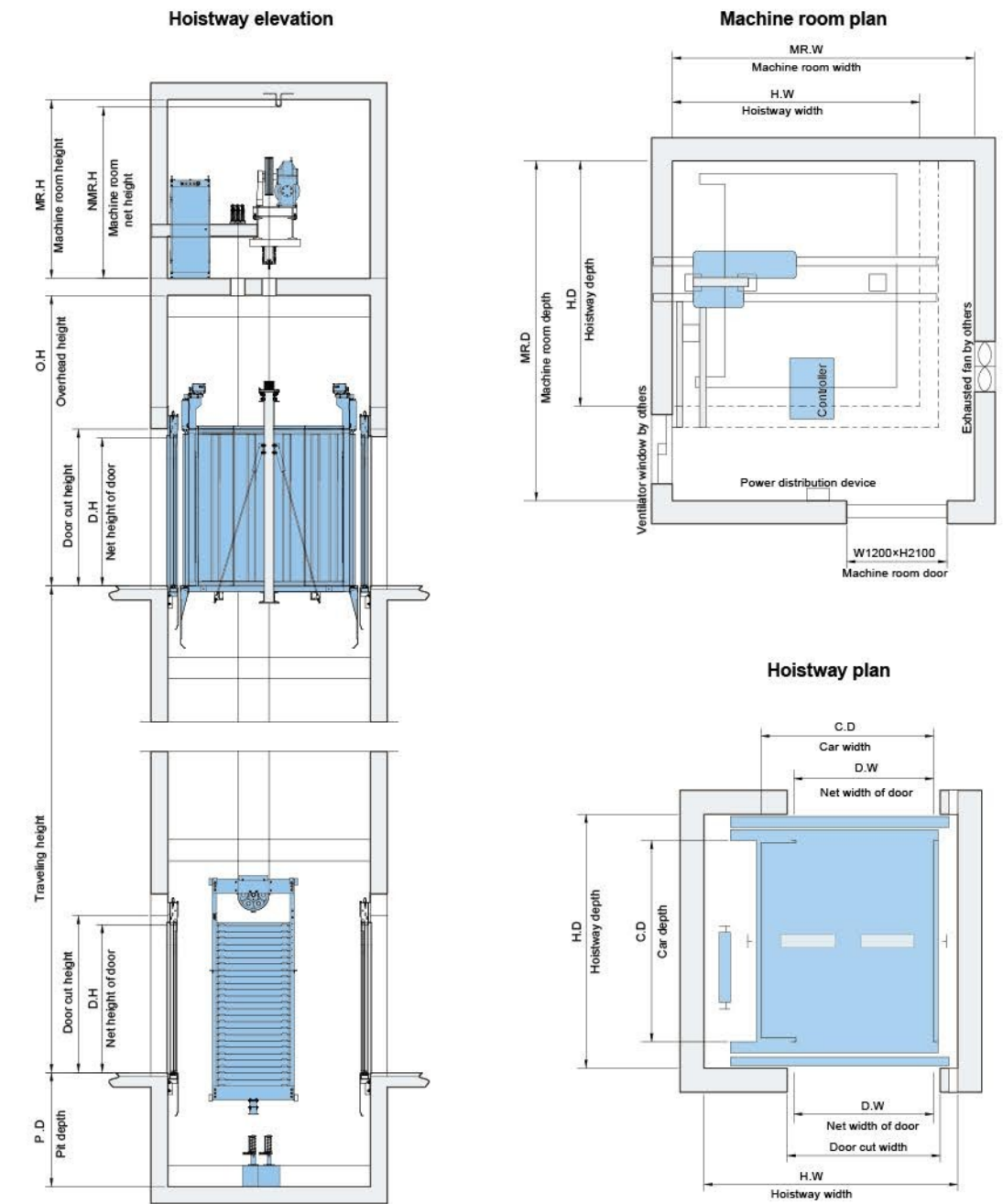

GRF machine room freight elevator specifications

Rated capacity (kg)	Rated speed (m/s)	Net size of car (mm)	Net size of door D.WxD.H (mm)		Hoistway size (mm)			Machine room size (mm)		Max. Traveling height (m)
		C.W x C.D	2P telescopic opening	4P Center opening	H.W x H.D	O.H	P.D	MR.W x MR.D	MR.H	
1000	0.5	1300x1750	1300x2200	—	2400x2150	4100	1400	2600x2400	2300	30
2000	0.5	1950x2150	1500x2200	1500x2200	2800x2600	4100	1400	2800x2600	2400	30
	1.0				2800x2600	4200	1500			
3000	0.5	2000x2900	—	2000x2200	3400x3400	4400	1500	3400x3400	2600	30
5000	0.25	2400x3600	—	2400x2400	4000x4100	4600	1600	4000x4100	2700	15

GRFN machine roomless freight elevator construction sketch

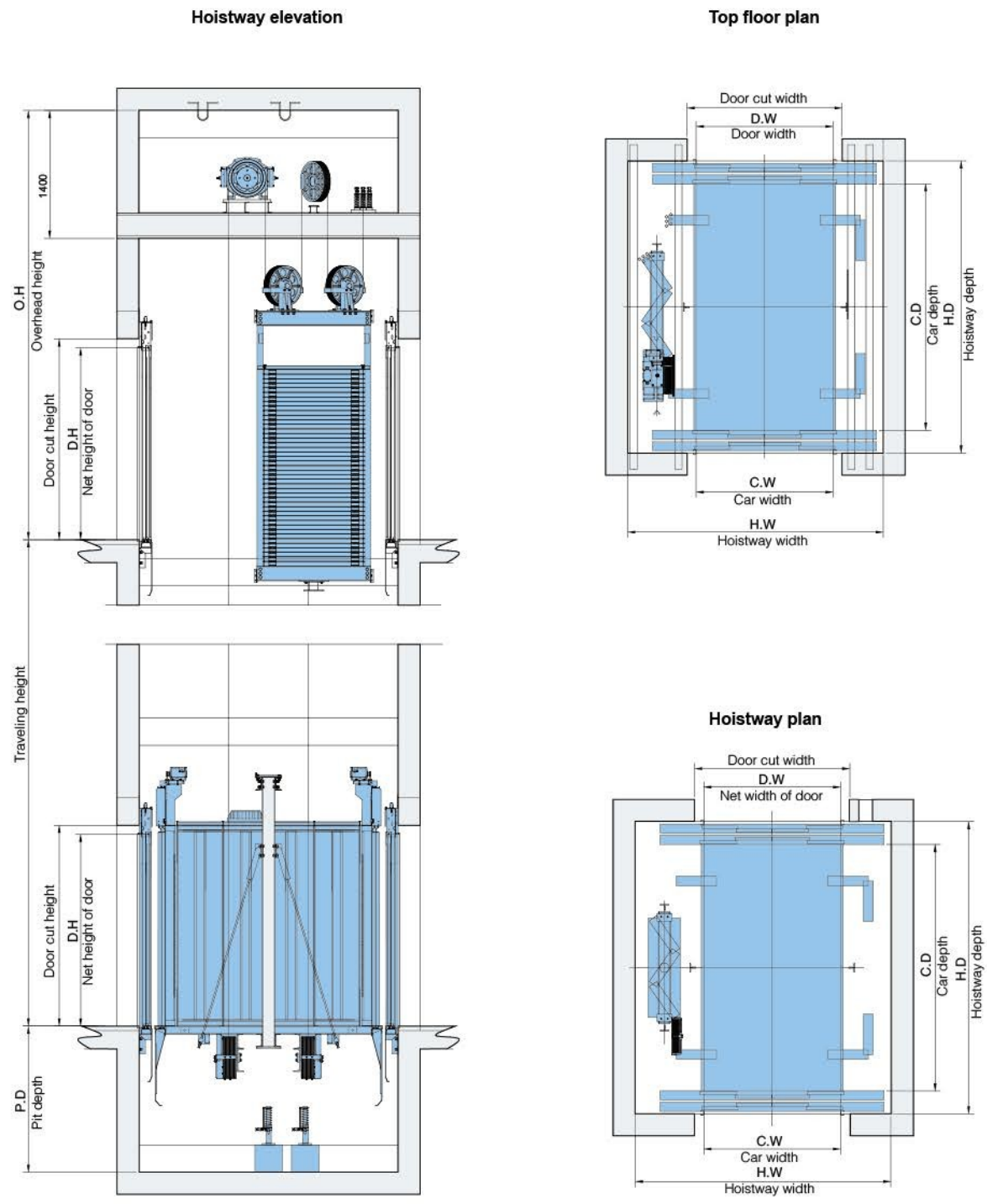

GRFN machine roomless freight elevator specifications

Rated capacity (kg)	Rated speed (m/s)	Net size of car (mm)		Net size of door D.W (mm)		Hoistway size (mm)			Traction ratio
		C.W x C.D	2P telescopic opening	4P Center opening	H.W x H.D	O.H	P.D		
2000	0.5	1500x2700	—	1500x2100	2800x3150	4700	1600	4:1	
2000	1.0	1500x2700	—	1500x2100	2800x3150	4800	1700	4:1	
3000	0.5	2000x2900	—	2000x2200	3550x3500	5000	1700	4:1	

GRA10 car elevator construction sketch

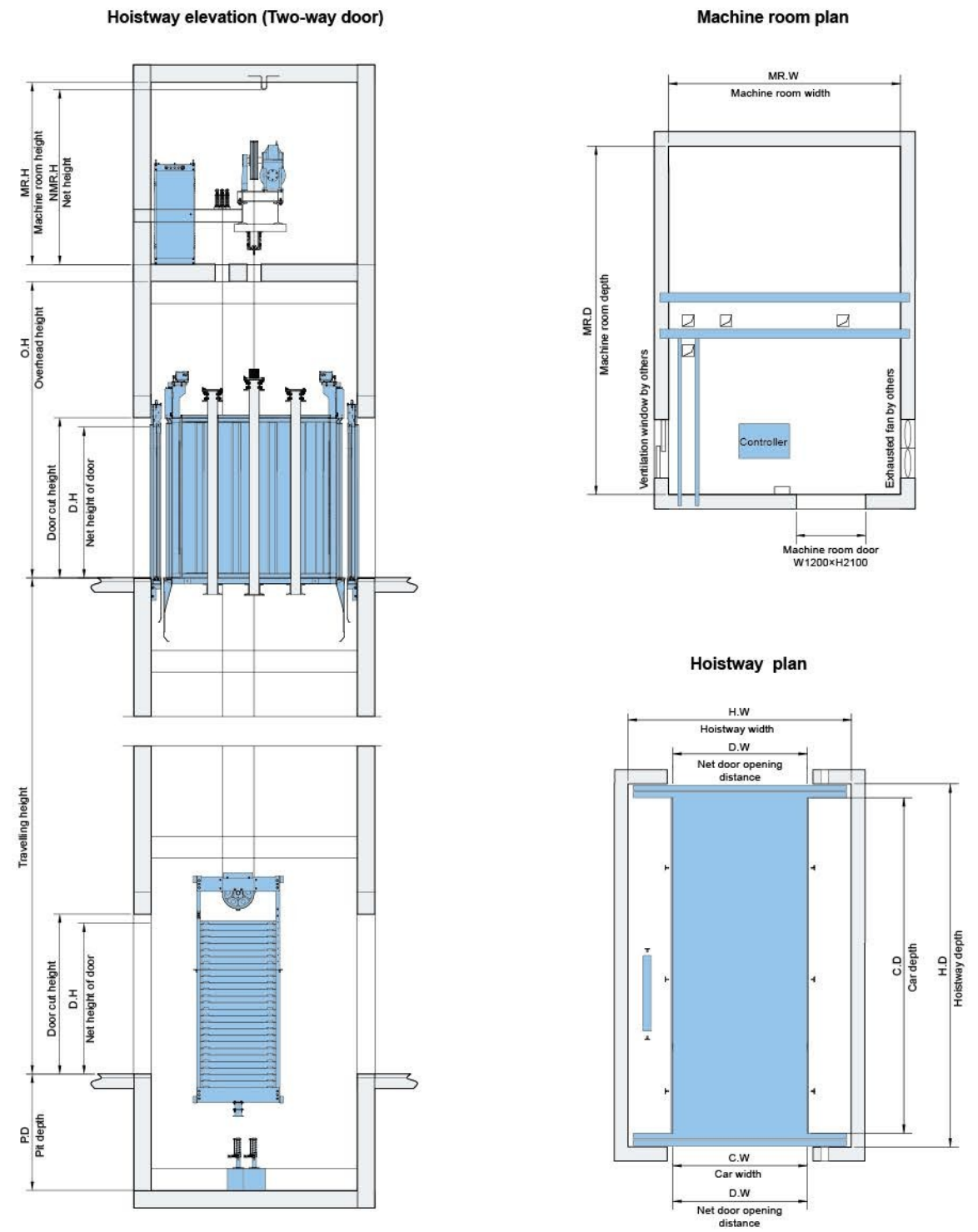

GRA10 car elevator specifications

(Kg) Rated capacity	(m/s) Rated speed	Net size of door (mm)			Net size of car (mm)			Hoistway size (mm)			Machine room size (mm)			O.H (mm)	P.D (mm)	Max. Traveling height (m)
		4P center opening	Width	Depth	Width	Depth	Height	Width	Depth	Height	Width	Depth	Height			
3000	0.5	2700x2200	2700	5500	2200	4400	6100	4400	6100	2700	4800	1700	30			
5000	0.25	2700x2200	2700	6000	2200	4400	6600	4400	6600	2700	4800	1700	15			

GRFH10 hydraulic freight elevator construction sketch

GRE20 escalator construction sketch (Indoor type and outdoor type)

30°

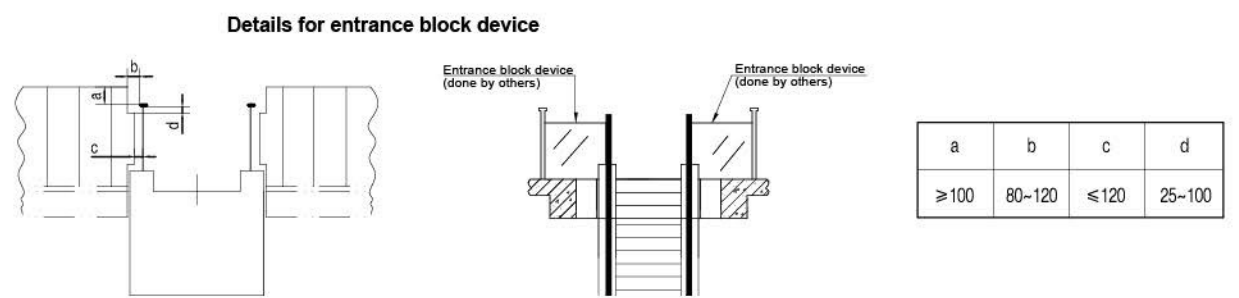
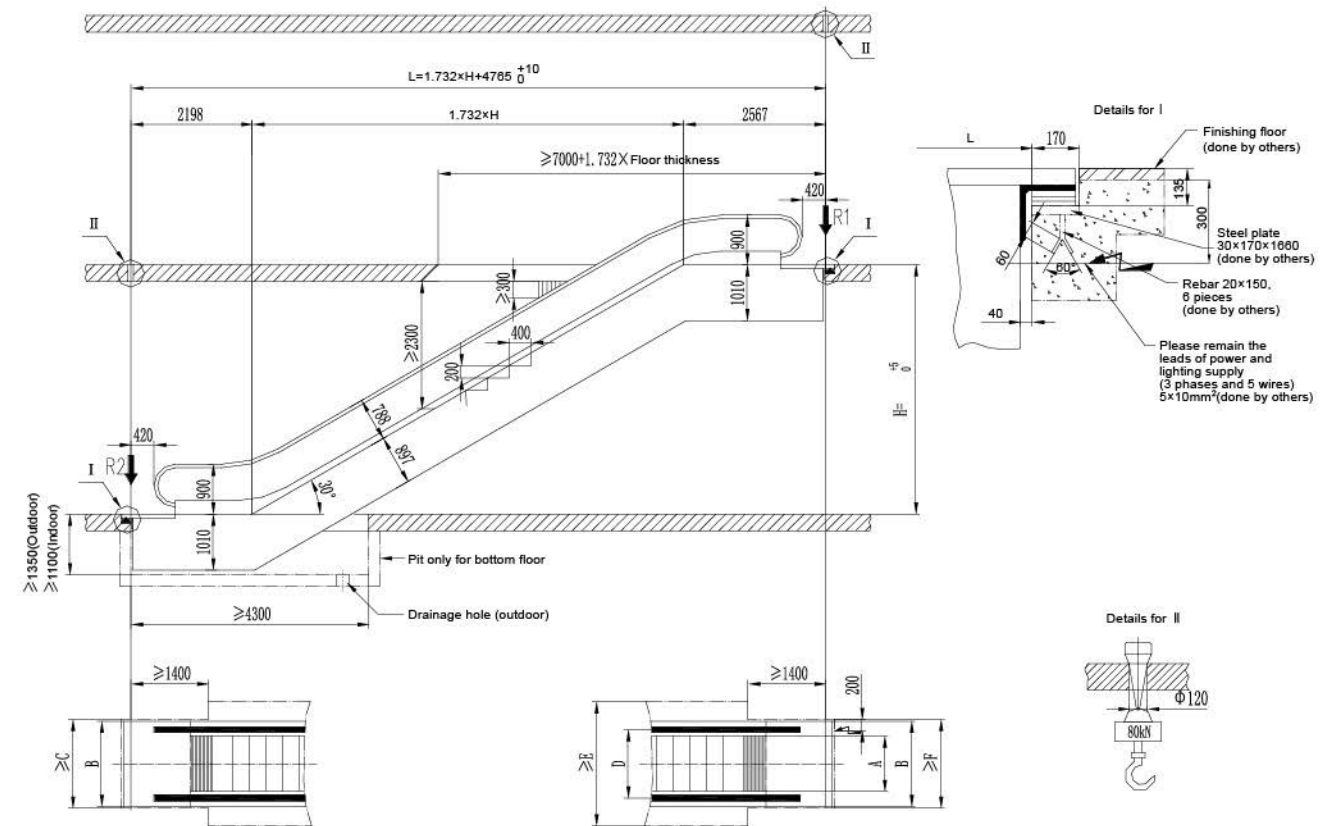
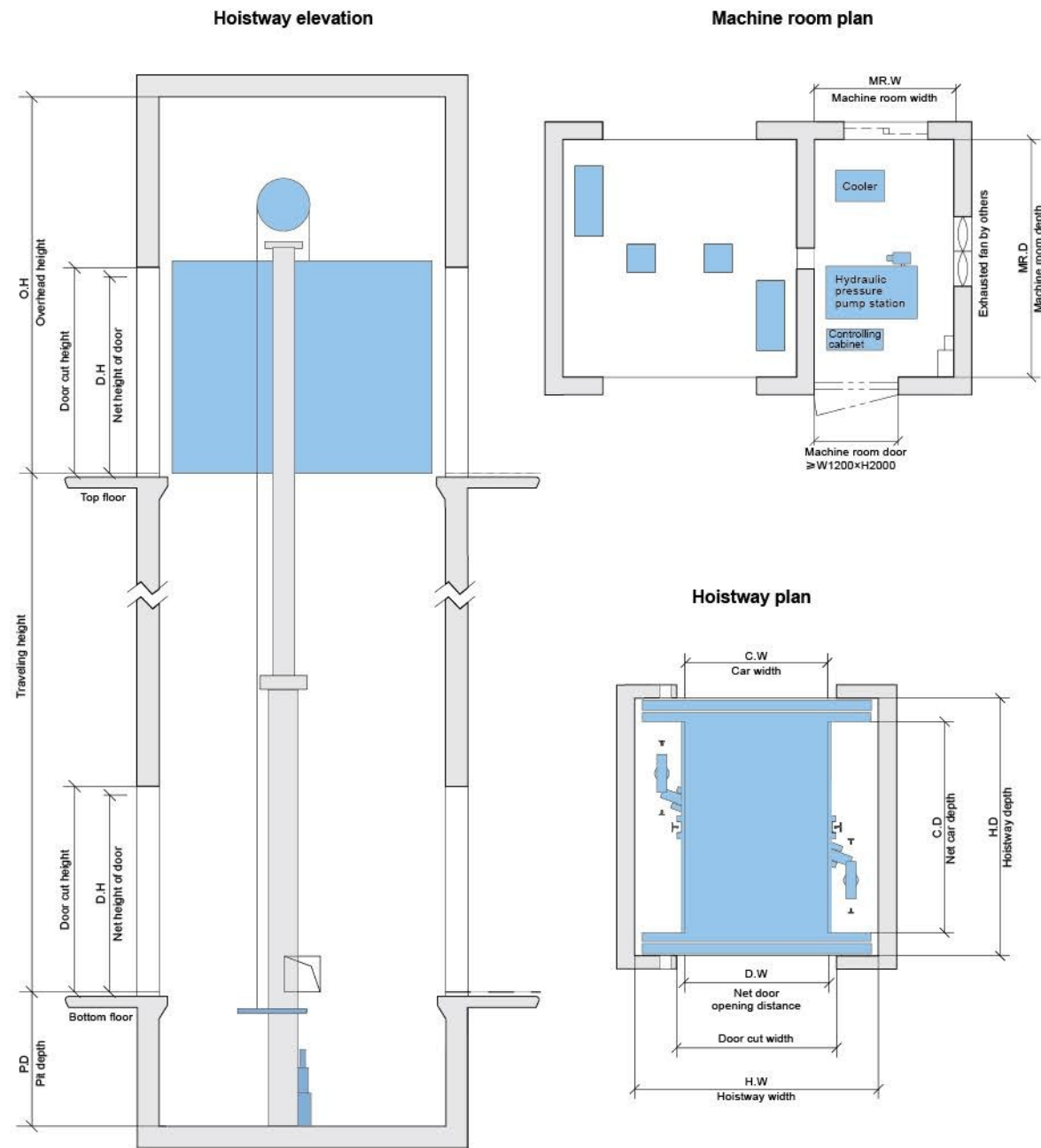

GRFH10 hydraulic freight elevator specifications

Rated capacity (Kg)	Rated speed (m/s)	Cylinder type	Net size of car (mm)		Net size of door (mm) D.W×D.H		Hoistway size (mm)			Machine room size (mm)		Max. Traveling height (m)
			C.W×C.D	2P Telescopic opening	4P Center opening	H.W×H.D	O.H	P.D	MR.W×MR.D	MR.H		
1000	0.5	1 cylinder 4 rails 4:2	1300×1750	1300×2200	—	2400×2150	4200	1550	2000×2150	2300	23.5	
2000	0.5	1 cylinder 4 rails 4:2	1500×2700	1500×2200	—	2800×3100	4200	1550	2000×3100	2300	23.5	
3000	0.25	2 cylinder 6 rails 2:1	2000×2900	—	2000×2200	3400×3350	4200	1550	2000×3350	2300	18	
3000	0.25	2 cylinder 6 rails 1:1	2000×2900	—	2000×2200	3400×3350	4200	1550	2000×3350	2300	9	
5000	0.25	2 cylinder 6 rails 2:1	2400×3800	—	2400×2400	4000×4050	4500	1700	2400×4050	2300	12	

Reaction force & power

Step width	600	800	1000	Remark
R1 (kN)	3.5×L+15.5	4×L+17	4.5×L+18.5	L measured by M
R2 (kN)	3.5×L+10	4×L+11	4.5×L+11.5	
Rise	3000 3500 4000 4500 5000 5500 6000			
Motor power	1000 5.5kW	8kW	11kW	
	800 5.5kW		8kW	
	600	5.5kW		

Standard specification and size

Escalator external width	A	600	800	1000
Escalator external width	B	1150	1350	1550
Civil opening width	C	1260	1460	1660
Distance between handrail centers	D	838	1038	1238
Civil opening width	E	1838	2038	2238
Civil opening width	F	1260	1460	1660

Note		Specification	
1. The sketch applies to civil construction of a single arrangement escalator with H ≤ 6m and below.		Type	GRE20
2. Upper end of truss should be extended for 417mm once step width 600mm chosen.		Speed	0.5m/s
3. Size measured by mm, some sizes may be changed. Subject to change without notice.		Rise	H= mm
		Inclination	30°
		Supporting force R1	kN
		Supporting force R2	kN
		Power supply	3P AC 380V 50HZ
		Lighting supply	1P AC 220V 50HZ

GRE20 escalator construction sketch (Indoor type and outdoor type)

30°

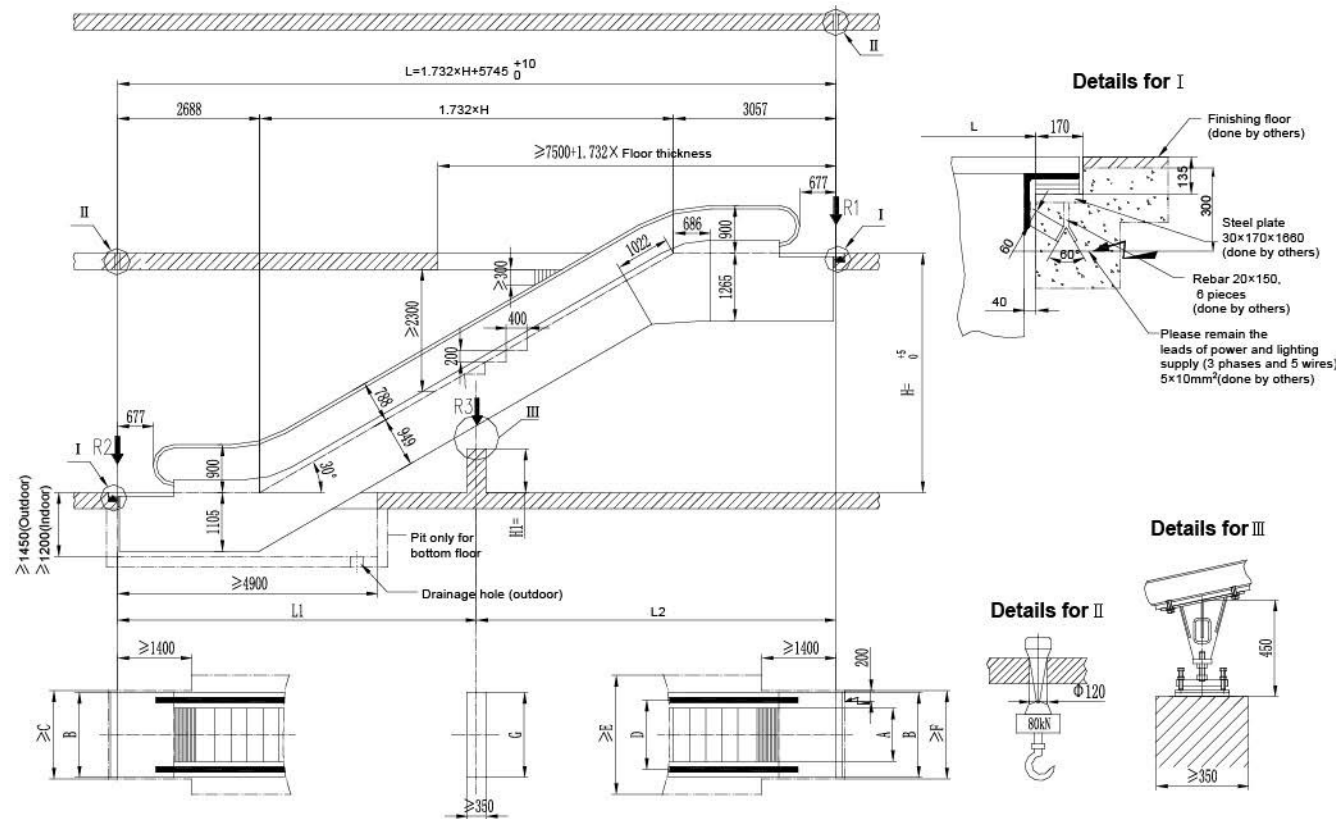

GRE20 escalator construction sketch (Indoor type and outdoor type)

35°

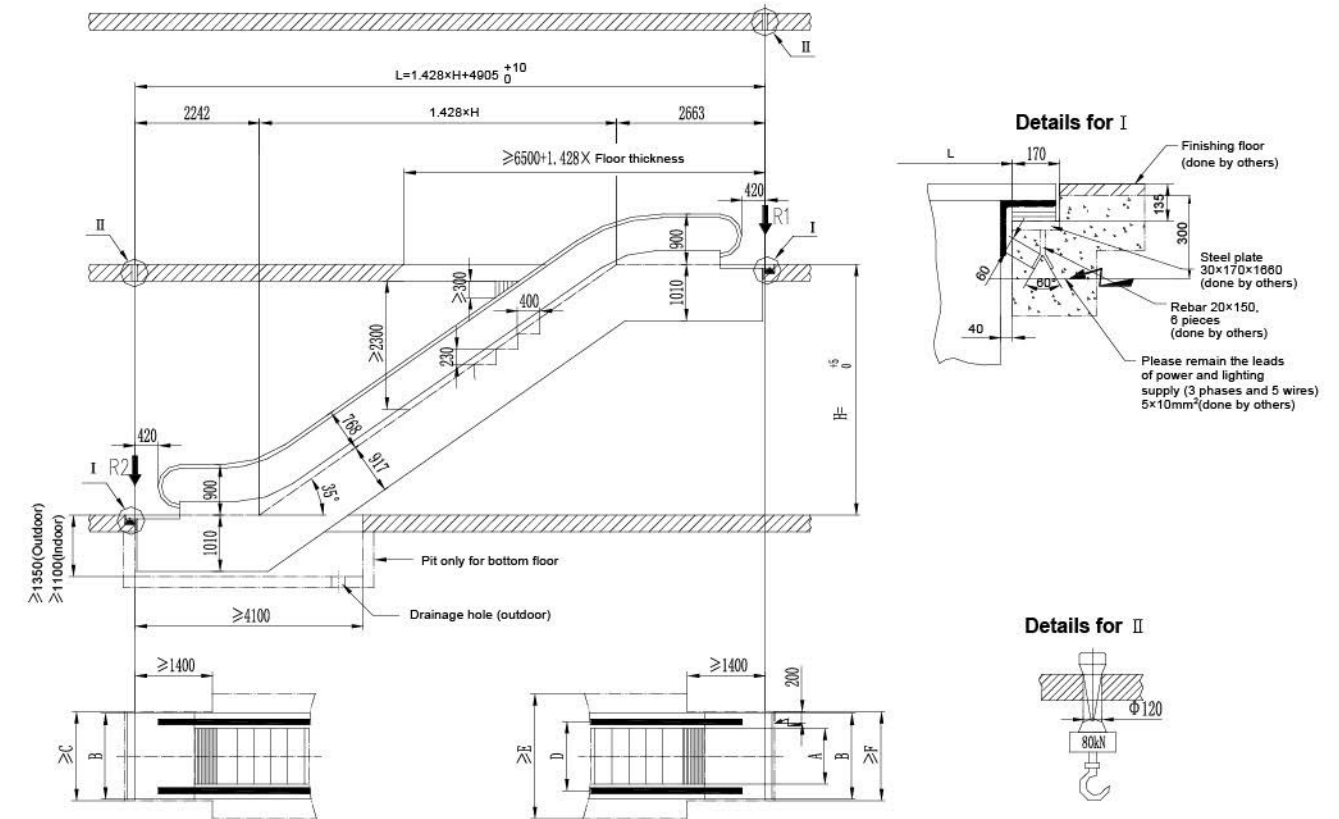

Details for entrance block device

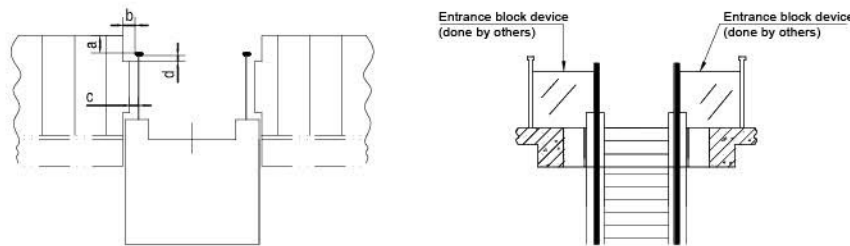

a	b	c	d
≥100	80~120	≤120	25~100

Details for entrance block device

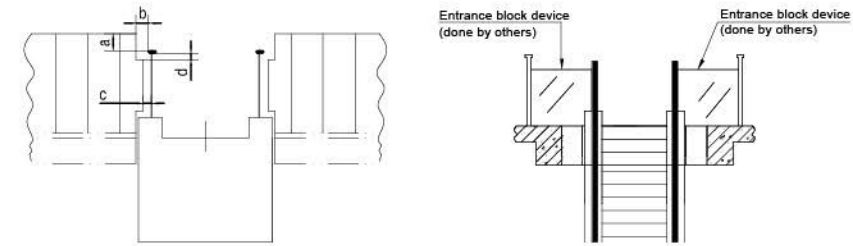

a	b	c	d
≥100	80~120	≤120	25~100

Reaction force

Step width	600	800	1000
R1 (kN)	4.1xL2+15.5	4.5xL2+16.1	5xL2+18.5
R2 (kN)	4.1xL1+7.8	4.5xL1+7.8	5xL1+8.5
R3 (kN)	4.25xL+9.5	4.5xL+10.5	5.2xL+11.5
Remark	L, L1, L2 measured by M; Value of L1 & L2 less than 15m.		
Rise	6100	7100	7500
Motor power	1000	15kW	
	800	11kW	
	600	8kW	11kW

Standard specification and size

Escalator external width	A	600	800	1000
Escalator external width	B	1150	1350	1550
Civil opening width	C	1260	1460	1660
Distance between handrail centers	D	838	1038	1238
Civil opening width	E	1910	2110	2310
Civil opening width	F	1260	1460	1660
Support base length	G	1200	1400	1600

Note

- The sketch applies to civil construction of a single arrangement escalator with 6m < H ≤ 7.5m and below.
- Upper end of truss should be extended for 417mm once step width 600mm chosen.
- Size measured by mm, some sizes may be changed. Subject to change without notice.

Specification

Type	GRE20
Speed	0.5m/s
Rise	H= mm
Inclination	30°
Supporting force R1	kN
Supporting force R2	kN
Supporting force R3	kN
Power supply	3P AC 380V 50HZ
Lighting supply	1P AC 220V 50HZ

Reaction force & power

Step width	600	800	1000	Remark			
R1 (kN)	3.5xL+15.5	4xL+17	4.5xL+18.5	L measured by M			
R2 (kN)	3.5xL+10	4xL+11	4.5xL+11.5				
Rise	3000	3500	4000		4500	5000	5500
Motor power	1000	5.5kW	8kW	11kW			
	800	5.5kW		8kW			
	600		5.5kW				

Standard specification and size

Escalator external width	A	600	800	1000
Escalator external width	B	1150	1350	1550
Civil opening width	C	1260	1460	1660
Distance between handrail centers	D	838	1038	1238
Civil opening width	E	1838	2038	2238
Civil opening width	F	1260	1460	1660

Note

- The sketch applies to civil construction of a single arrangement escalator with H ≤ 6m and below.
- Upper end of truss should be extended for 417mm once step width 600mm chosen.
- Size measured by mm, some sizes may be changed. Subject to change without notice.

Specification

Type	GRE20
Speed	0.5m/s
Rise	H= mm
Inclination	35°
Supporting force R1	kN
Supporting force R2	kN
Power supply	3P AC 380V 50HZ
Lighting supply	1P AC 220V 50HZ

GRE30 escalator construction sketch (Indoor type and outdoor type)

30°

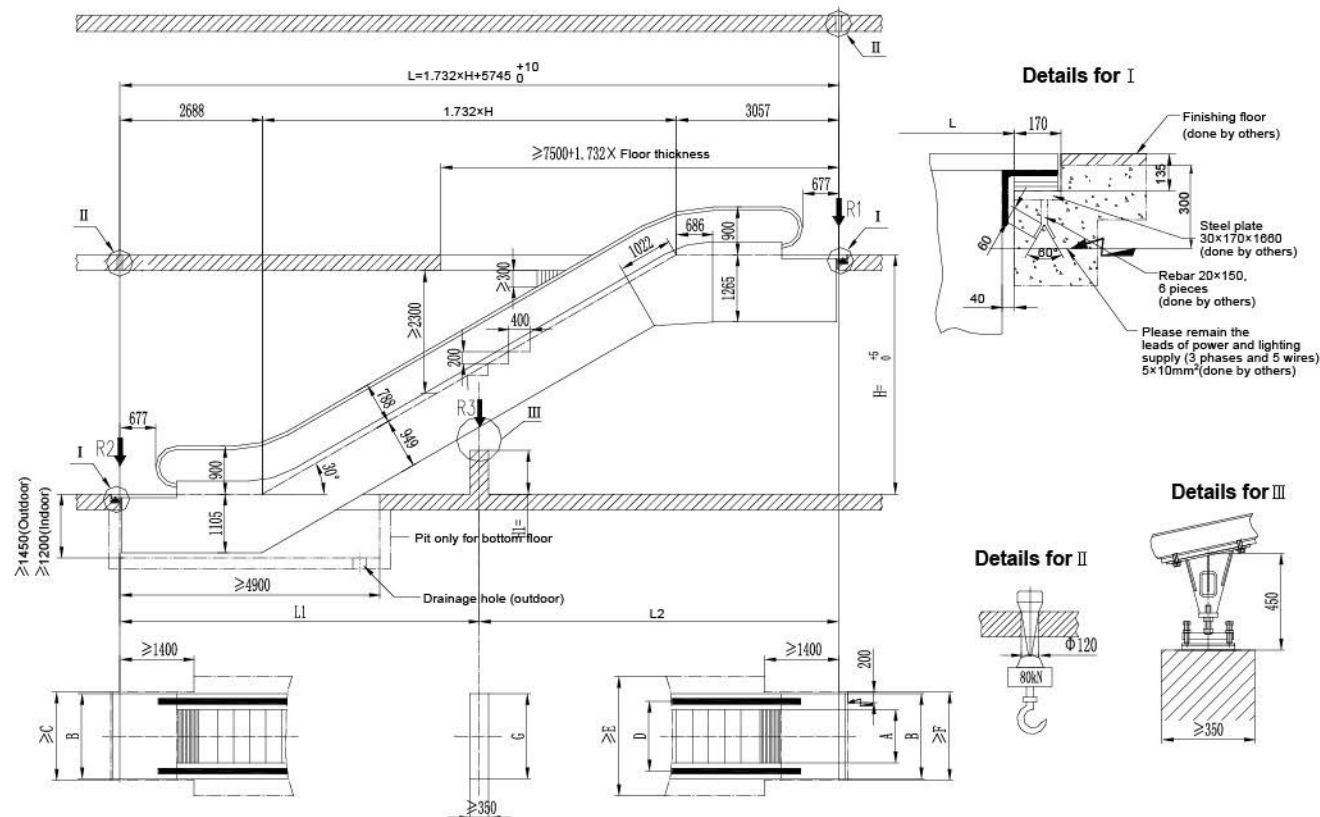

GRE50 public transport escalator construction sketch (Indoor type and outdoor type)

30°

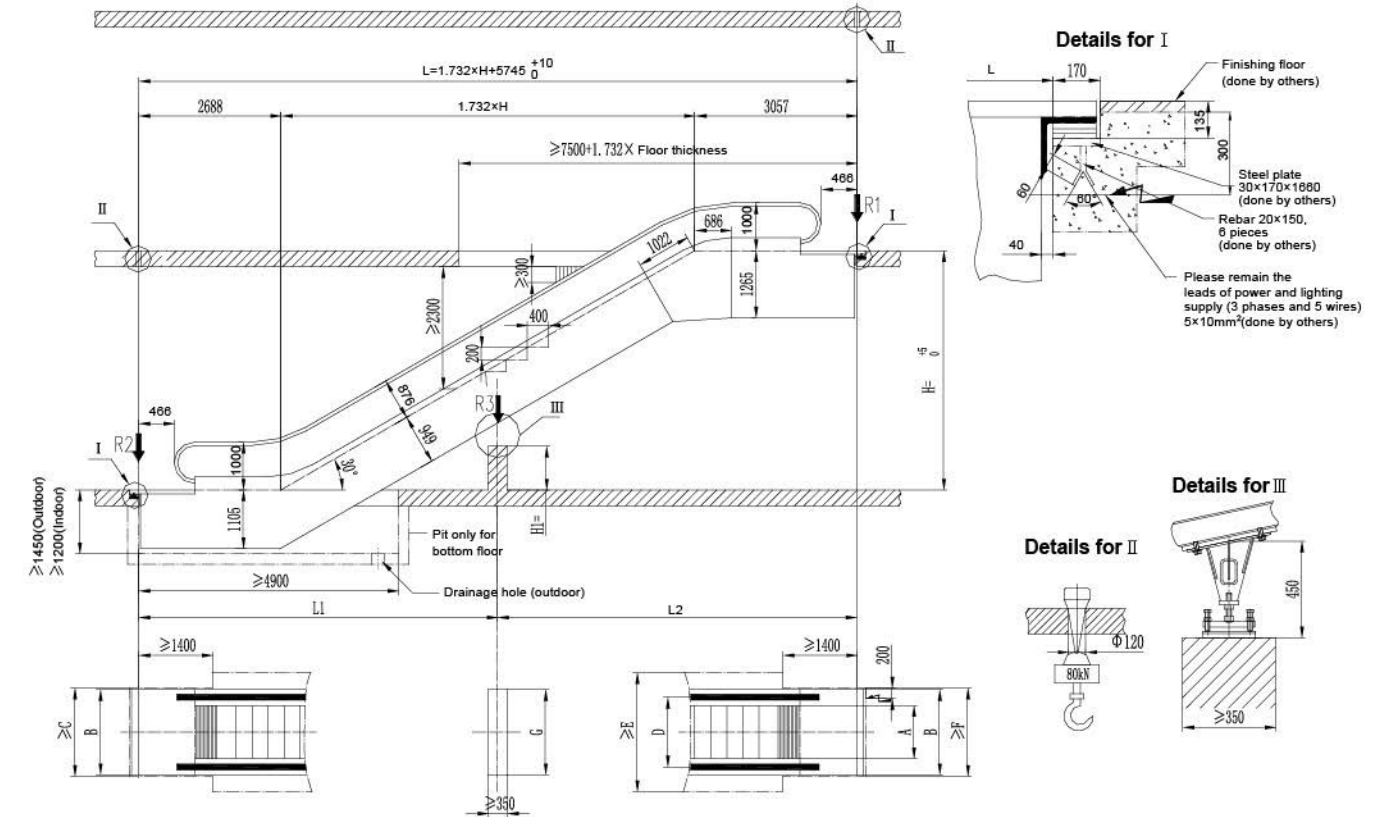

Details for entrance block device

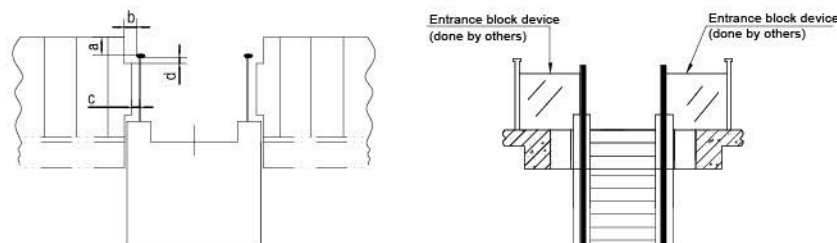

a	b	c	d
≥ 100	80~120	≤ 120	25~100

Details for entrance block device

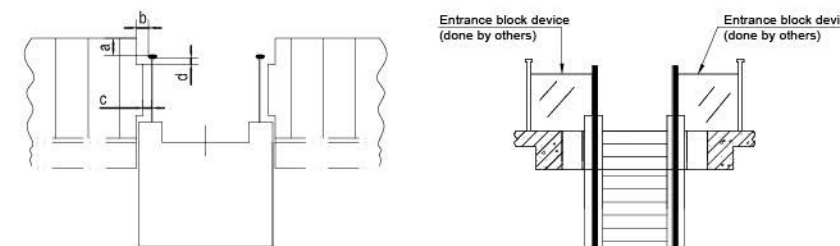

a	b	c	d
≥ 100	80~120	≤ 120	25~100

Reaction force

Step width	600	800	1000
R1 (kN)	4.1×L2+16.5	4.5×L2+17.1	5×L2+18.5
R2 (kN)	4.1×L1+8.8	4.5×L1+8.8	5×L1+9.5
R3 (kN)	4.25×L1+10.5	4.5×L1+11.5	5.2×L1+12.5
Remark	L, L1, L2 measured by M; Value of L1 & L2 less than 15m.		

Standard specification and size

Escalator external width	A	600	800	1000
Escalator external width	B	1200	1400	1600
Civil opening width	C	1260	1460	1660
Distance between handrail centers	D	838	1038	1238
Civil opening width	E	1910	2110	2310
Civil opening width	F	1260	1460	1660
Support base length	G	1200	1400	1600

Note

- The sketch applies to civil construction of a single arrangement escalator with H ≤ 18m and below.
- Upper end of truss should be extended for 417mm once step width 800mm chosen.
- Size measured by mm, some sizes may be changed. Subject to change without notice.

Specification

Type	GRE30	
Speed	0.5m/s (0.85m/s)	
Rise	H= mm	
Inclination	30°	
Supporting force R1	kN	
Supporting force R2	kN	
Supporting force R3	kN	
Power	Power supply	3P AC 380V 50HZ
	Lighting supply	1P AC 220V 50HZ

Reaction force

Step width	600	800	1000
R1 (kN)	4.1×L2+16.5	4.5×L2+17.1	5×L2+18.5
R2 (kN)	4.1×L1+8.8	4.5×L1+8.8	5×L1+9.5
R3 (kN)	4.25×L1+10.5	4.5×L1+11.5	5.2×L1+12.5
Remark	L, L1, L2 measured by M; Value of L1 & L2 less than 15m.		

Standard specification and size

Escalator external width	A	600	800	1000
Escalator external width	B	1200	1400	1600
Civil opening width	C	1260	1460	1660
Distance between handrail centers	D	838	1038	1238
Civil opening width	E	1910	2110	2310
Civil opening width	F	1260	1460	1660
Support base length	G	1200	1400	1600

Note

- The sketch applies to civil construction of a single arrangement escalator with 6m < H ≤ 30m and below.
- Upper end of truss should be extended for 417mm once step width 800mm chosen.
- Size measured by mm, some sizes may be changed. Subject to change without notice.

Specification

Type	GRE50	
Speed	0.5m/s (0.85m/s)	
Rise	H= mm	
Inclination	30°	
Supporting force R1	kN	
Supporting force R2	kN	
Supporting force R3	kN	
Power	Power supply	3P AC 380V 50HZ
	Lighting supply	1P AC 220V 50HZ

GRM15 moving walk construction sketch (Indoor type and outdoor type)

0°

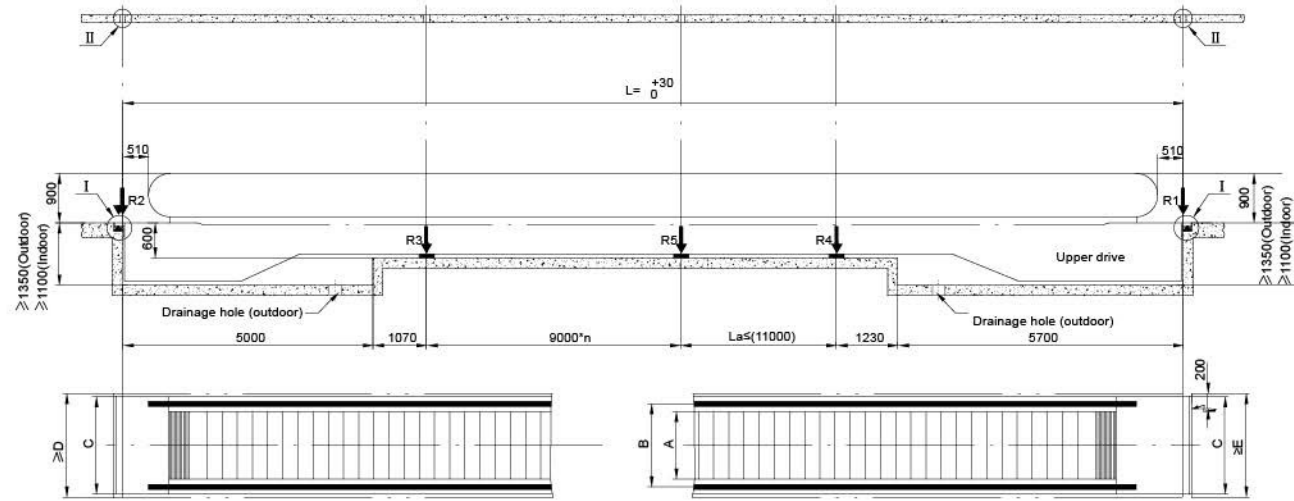

Details for II

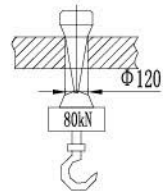

Details for entrance block device

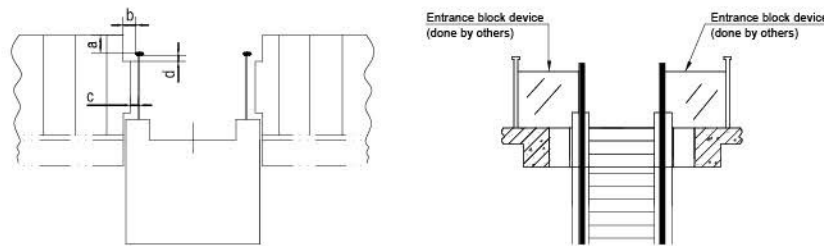

Details for I

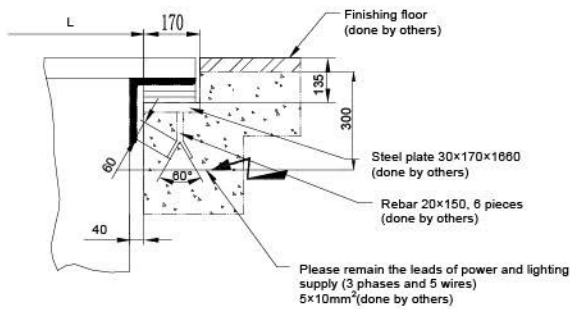

a	b	c	d
≥ 100	80~120	≤ 120	25~100

Pallet width	800	1000	Pallet width	800	1000
R1	32kN	39kN	A	800	1000
R2	31kN	33kN	B	1100	1310
R3	49kN	55kN	C	1400	1600
R4	50kN	57kN	D	1480	1660
R5	43kN	51kN	E	1480	1660

Note		Specification	
1. The sketch applies to civil construction of a single arrangement moving walk with L ≤ 150m and below.		Type	GRM15
2. Size measured by mm, some sizes may be changed. Subject to change without notice.		Speed	0.5m/s
		Horizontal span	L= mm
		Inclination	0°
		Supporting force R1	kN
		Supporting force R2	kN
		Supporting force R3	kN
		Supporting force R4	kN
		Supporting force R5	kN
		Power supply	3P AC 380V 50HZ
		Lighting supply	1P AC 220V 50HZ

GRM20 moving walk construction sketch (Indoor type and outdoor type)

12°

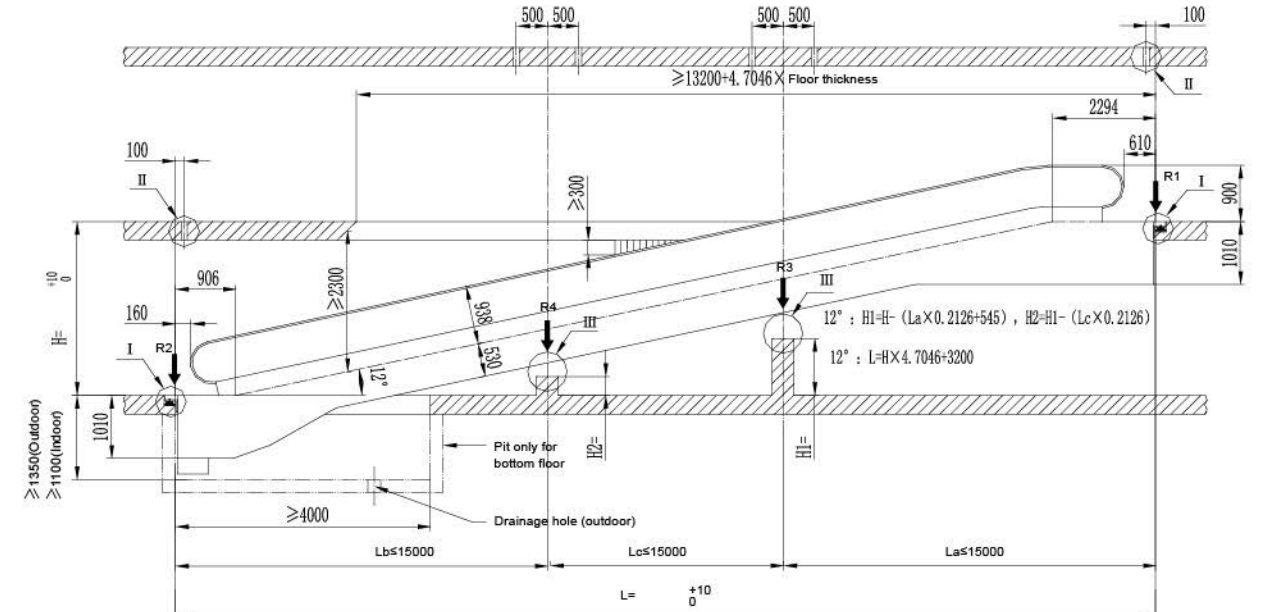

Details for I

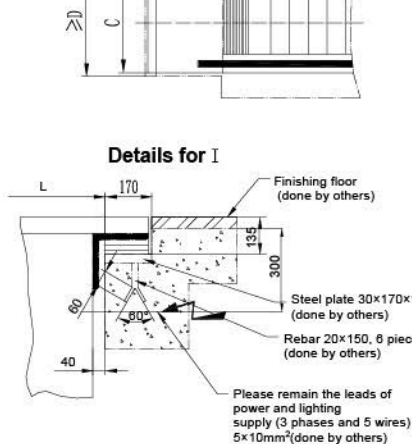

Details for II

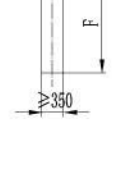

Details for III



Details for entrance block device

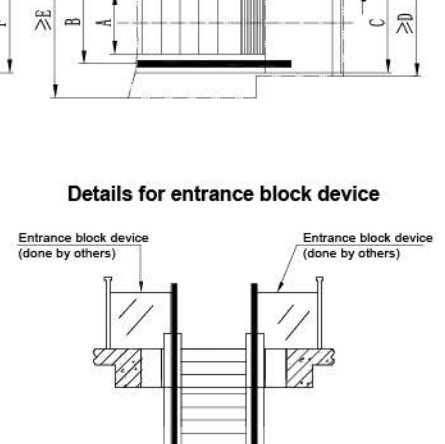

a	b	c	d
≥ 100	80~120	≤ 120	25~100

Supporting force	q	M	N	Pallet width									
				800	1000								
800	0.0039	9.5	4.5	A	800	1000							
				B	1110	1310							
				C	1400	1600							
				D	1460	1660							
1000	0.0045	11	5	E	2110	2310							
				F	1400	1600							
				La									
				Lb									
12°	1601	2508	-	-	-	-							
							2509	5695	1	-	L/2	L/2	-
											L/3	L/3	L/3
							5696	6000	1	1	L/3	L/3	L/3
6100	8000	1	1	L/3	L/3	L/3							

Details for entrance block device

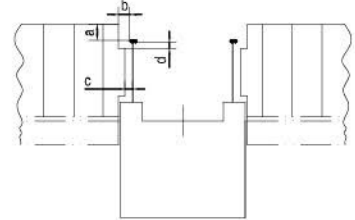

Supporting force

No middle support (kN)	Single middle support (kN)	Double middle supports (kN)
R1=L×q×M	R1=La×q×M	R1=La×q×M
R2=L×q×N	R2=Lb×q×N	R2=Lb×q×N
R3=(La+Lb)×1.3×q	R3=(La+Lc)×1.3×q	R3=(La+Lc)×1.3×q
R4=(Lb+Lc)×1.3×q	R4=(Lb+Lc)×1.3×q	R4=(Lb+Lc)×1.3×q

Note		Specification	
1. The sketch applies to civil construction of a single arrangement moving walk with H ≤ 8m and below.		Type	GRM20
2. Size measured by mm, some sizes may be changed. Subject to change without notice.		Speed	0.5m/s
		Rise	H= mm
		Inclination	12°
		Supporting force R1	kN
		Supporting force R2	kN
		Supporting force R3	kN
		Supporting force R4	kN
		Power supply	3P AC 380V 50HZ
		Lighting supply	1P AC 220V 50HZ

Classical projects

After years of market accumulation, Sicher has become an excellent all-around building & traffic service facilitator and also the ideal choice for lots of construction projects depending on its reliable quality, professional after sales service and rich products items. Sicher has successfully provided completed vertical traffic solution for government buildings, commercial buildings, residential projects, culture landmark etc. all over the world and wins the consistent high praise and trust from customers.



Shanghai Expo Korea Enterprise Joint Museum-Shanghai

MARINA Shopping Mall-Uzbekistan

Senamalancha, Dhaka Cantonment-Bangladesh



Marins Park Hotel Novosibirsk-Russia



Kunming Metro Line 6-Yunnan



EXPO 2017 Astana Turkey Pavillion-Kazakhstan



Guadalajara Metro Line 3-Mexico



Acapulco International Airport-Mexico



Angkor Duty Free Mall-Cambodia



Jomo Kenyatta International Airport-Nairobi



Moi International Airport-Mombasa



Embassy of the State of Palestine-Pakistan



Urumqi Railway Station-Xinjiang



Public Authority of Agriculture Affairs & Fish Resources-Kuwait



Orient Tower-UAE



BASSAM Building-Libya



Parliament House Mandalay-Myanmar



NILE Plaza-Egypt



TEHRAN Railway Station-Iran



Central Bazaar-India



ITECC Market-Laos

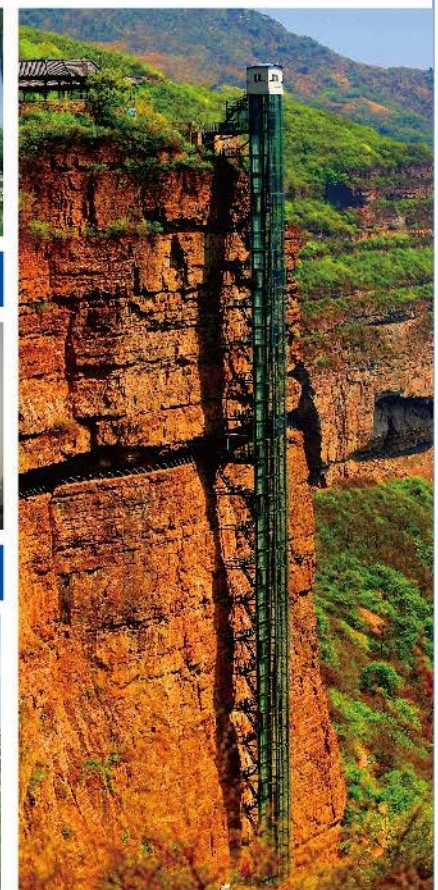

Main MTK-Azerbaijan



Jeddah Hotel-Saudi Arabia



ESKALA Shop-Brazil



Indeco And Findeco Houses-Zambia



Lanzhou Zhongchuan International Airport-Gansu



Atlas complex shopping mall-Iran



Bombonera Stadium-Mexico



Ashgabat Park-Uzbekistan

Linzhou Tianpin Mountain-Henan